

JVC

SERVICE MANUAL

COMPACT COMPONENT CDR SYSTEM

NX-CDR7

Area Suffix	
J	U.S.A.
C	Canada

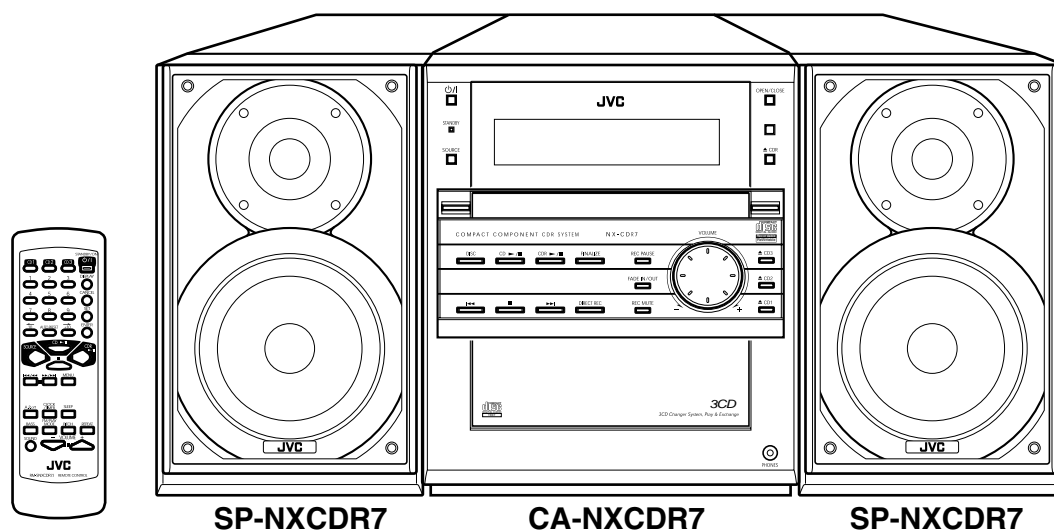

SP-NXCDR7

CA-NXCDR7

SP-NXCDR7



Contents

Safety precautions	1-2
Important for laser products	1-3
Importance administering point on the safety	1-4
Preventing static electricity	1-5
Disassembly method	1-6
Adjustment method	1-28
Flow of functional operation untill TOC read	1-31
Maintenance of laser pickup	1-32
Replacement of laser pickup	1-32
Description of major ICs	1-33~48

Safety Precautions

1. This design of this product contains special hardware and many circuits and components specially for safety purposes. For continued protection, no changes should be made to the original design unless authorized in writing by the manufacturer. Replacement parts must be identical to those used in the original circuits. Services should be performed by qualified personnel only.
2. Alterations of the design or circuitry of the product should not be made. Any design alterations of the product should not be made. Any design alterations or additions will void the manufacturer's warranty and will further relieve the manufacture of responsibility for personal injury or property damage resulting therefrom.
3. Many electrical and mechanical parts in the products have special safety-related characteristics. These characteristics are often not evident from visual inspection nor can the protection afforded by them necessarily be obtained by using replacement components rated for higher voltage, wattage, etc. Replacement parts which have these special safety characteristics are identified in the Parts List of Service Manual. Electrical components having such features are identified by shading on the schematics and by (\triangle) on the Parts List in the Service Manual. The use of a substitute replacement which does not have the same safety characteristics as the recommended replacement parts shown in the Parts List of Service Manual may create shock, fire, or other hazards.
4. The leads in the products are routed and dressed with ties, clamps, tubings, barriers and the like to be separated from live parts, high temperature parts, moving parts and/or sharp edges for the prevention of electric shock and fire hazard. When service is required, the original lead routing and dress should be observed, and it should be confirmed that they have been returned to normal, after re-assembling.
5. Leakage current check (Electrical shock hazard testing)

After re-assembling the product, always perform an isolation check on the exposed metal parts of the product (antenna terminals, knobs, metal cabinet, screw heads, headphone jack, control shafts, etc.) to be sure the product is safe to operate without danger of electrical shock.

Do not use a line isolation transformer during this check.

 - Plug the AC line cord directly into the AC outlet. Using a "Leakage Current Tester", measure the leakage current from each exposed metal parts of the cabinet, particularly any exposed metal part having a return path to the chassis, to a known good earth ground. Any leakage current must not exceed 0.5mA AC (r.m.s.).
 - Alternate check method

Plug the AC line cord directly into the AC outlet. Use an AC voltmeter having, 1,000 ohms per volt or more sensitivity in the following manner. Connect a 1,500 Ω 10W resistor paralleled by a 0.15 μ F AC-type capacitor between an exposed metal part and a known good earth ground. Measure the AC voltage across the resistor with the AC voltmeter.

Move the resistor connection to each exposed metal part, particularly any exposed metal part having a return path to the chassis, and measure the AC voltage across the resistor. Now, reverse the plug in the AC outlet and repeat each measurement. Voltage measured any must not exceed 0.75 V AC (r.m.s.). This corresponds to 0.5 mA AC (r.m.s.).

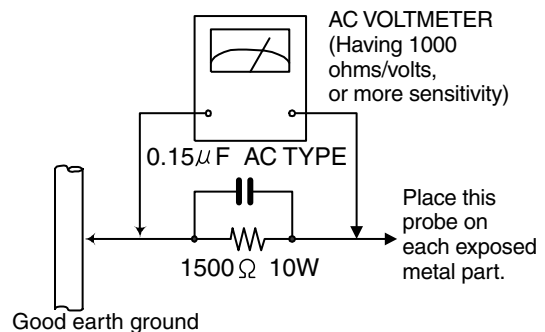

Warning

1. This equipment has been designed and manufactured to meet international safety standards.
2. It is the legal responsibility of the repairer to ensure that these safety standards are maintained.
3. Repairs must be made in accordance with the relevant safety standards.
4. It is essential that safety critical components are replaced by approved parts.
5. If mains voltage selector is provided, check setting for local voltage.

CAUTION

Burrs formed during molding may be left over on some parts of the chassis. Therefore, pay attention to such burrs in the case of preforming repair of this system.

In regard with component parts appearing on the silk-screen printed side (parts side) of the PWB diagrams, the parts that are printed over with black such as the resistor (■), diode (▣) and ICP (●) or identified by the " \triangle " mark nearby are critical for safety.

When replacing them, be sure to use the parts of the same type and rating as specified by the manufacturer. (Except the J and C version)

Important for laser products

1.CLASS 1 LASER PRODUCT

2.DANGER : Invisible laser radiation when open and interlock failed or defeated. Avoid direct exposure to beam.

3.CAUTION : There are no serviceable parts inside the Laser Unit. Do not disassemble the Laser Unit. Replace the complete Laser Unit if it malfunctions.

4.CAUTION : The compact disc player uses invisible laserradiation and is equipped with safety switches which prevent emission of radiation when the drawer is open and the safety interlocks have failed or are defeated. It is dangerous to defeat the safety switches.

5.CAUTION : If safety switches malfunction, the laser is able to function.

6.CAUTION : Use of controls, adjustments or performance of procedures other than those specified herein may result in hazardous radiation exposure.

⚠ CAUTION Please use enough caution not to see the beam directly or touch it in case of an adjustment or operation check.

VARNING : Osynlig laserstrålning är denna del är öppnad och spårren är urkopplad. Betrakta ej strålen.

VARO : Avattaessa ja suojalukitus ohitettaessa olet alltiina näkymättömälle lasersäteilylle.Älä katso säteeseen.

ADVARSEL : Usynlig laserstrålning ved åbning , når sikkerhedsafbrydere er ude af funktion. Undgå udsættelse for stråling.

ADVARSEL : Usynlig laserstrålning ved åbning,når sikkerhetsbryteren er avslott. unngå utsettelse for stråling.

REPRODUCTION AND POSITION OF LABELS

WARNING LABEL

DANGER : Invisibile laser radiation when open and interlock or defeated.
AVOID DIRECT EXPOSURE TO BEAM (e)

VARO : Avattaessa ja suojalukitus ohitettaessa olet alltiina näkymättömälle lasersäteilylle.Älä katso säteeseen. (d)

VARNING : Osynlig laserstrålning är denna del är öppnad och spårren är urkopplad. Betrakta ej strålen. (s)

ADVARSEL :Usynlig laserstrålning ved åbning , når sikkerhedsafbrydere er ude af funktion. Undgå udsættelse for stråling. (f)

**CLASS 1
LASER PRODUCT**

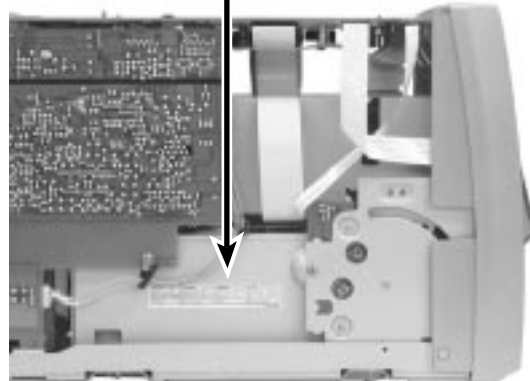
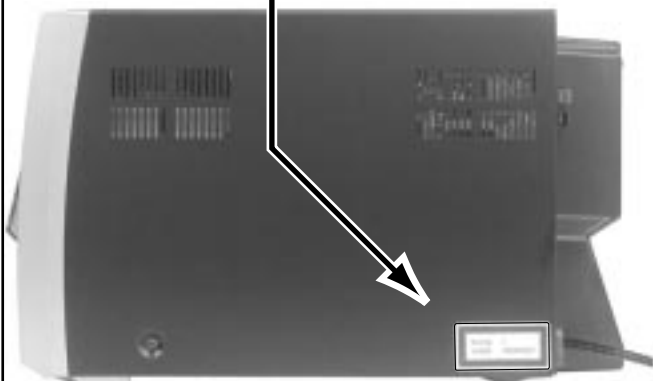

Importance administering point on the safety

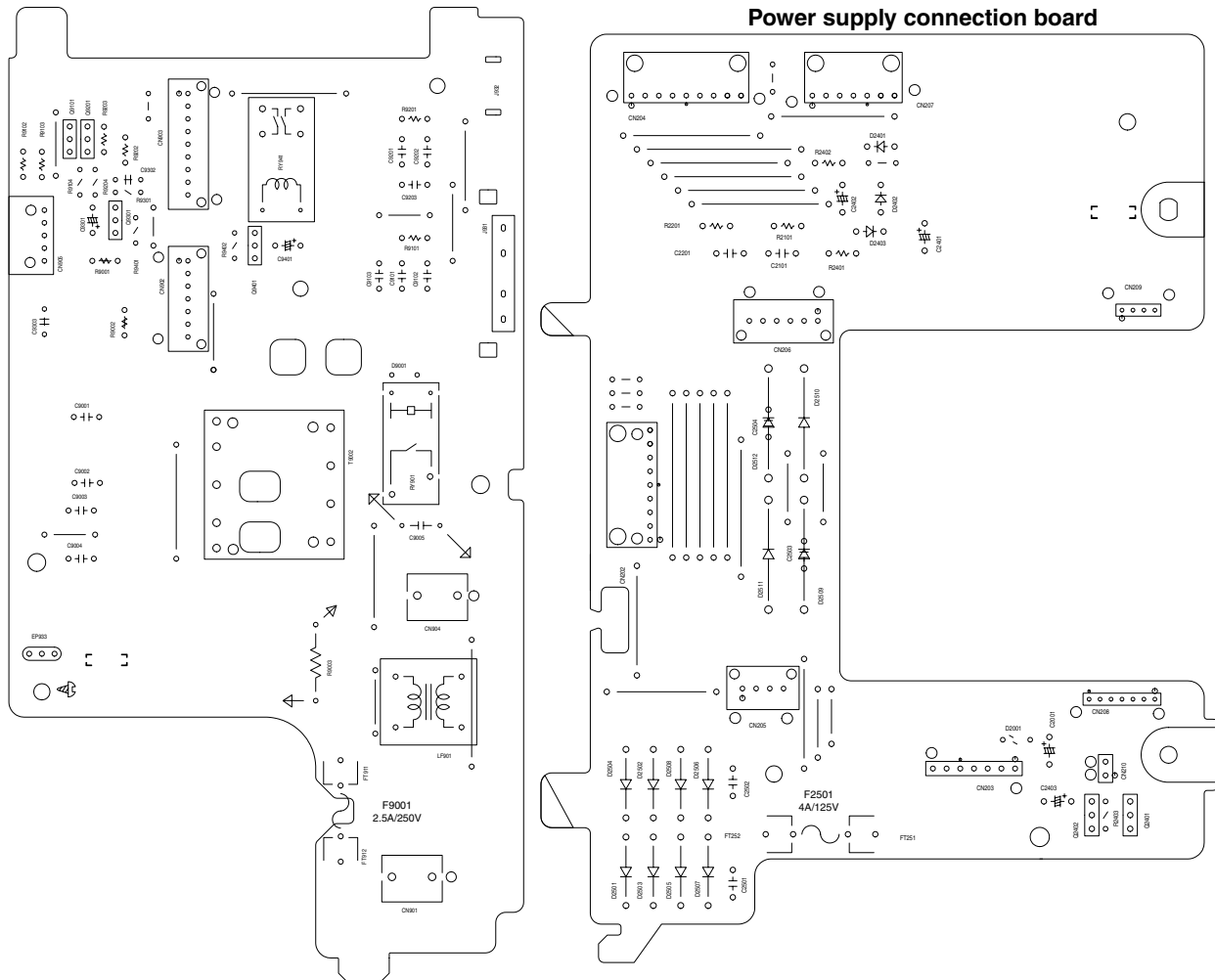

For USA and Canada / pour États - Unis d' Amérique et Canada

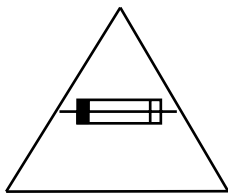

Caution: For continued protection against risk of fire, replace only with same type 2.5A/250V for F9001 and 4A/125V. This symbol specifies type of fast operating fuse.

Précaution: Pour éviter risques de feux, remplacez le fusible de sûreté de F9001 comme le même type que 2.5A/250V, et 4A/125V pour F8911 et F8921. Ce sont des fusibles sûretés qui fonctionnent rapide.

Preventing static electricity

Electrostatic discharge (ESD), which occurs when static electricity stored in the body, fabric, etc. is discharged, can destroy the laser diode in the traverse unit (optical pickup). Take care to prevent this when performing repairs.

1.1. Grounding to prevent damage by static electricity

Static electricity in the work area can destroy the optical pickup (laser diode) in devices such as DVD players. Be careful to use proper grounding in the area where repairs are being performed.

1.1.1. Ground the workbench

1. Ground the workbench by laying conductive material (such as a conductive sheet) or an iron plate over it before placing the traverse unit (optical pickup) on it.

1.1.2. Ground yourself

1. Use an anti-static wrist strap to release any static electricity built up in your body.

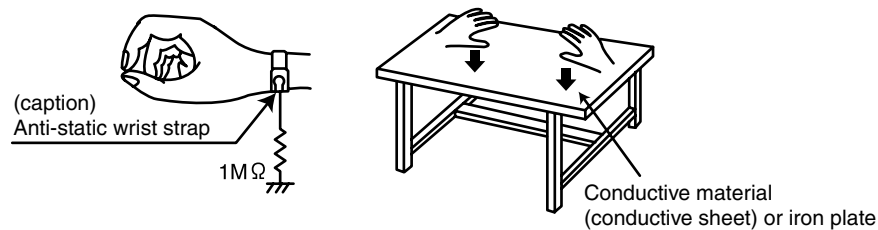

1.1.3. Handling the optical pickup

1. In order to maintain quality during transport and before installation, both sides of the laser diode on the replacement optical pickup are shorted. After replacement, return the shorted parts to their original condition. (Refer to the text.)
2. Do not use a tester to check the condition of the laser diode in the optical pickup. The tester's internal power source can easily destroy the laser diode.

1.2. Handling the traverse unit (optical pickup)

1. Do not subject the traverse unit (optical pickup) to strong shocks, as it is a sensitive, complex unit.
2. Cut off the shorted part of the flexible cable using nippers, etc. after replacing the optical pickup. For specific details, refer to the replacement procedure in the text. Remove the anti-static pin when replacing the traverse unit. Be careful not to take too long a time when attaching it to the connector.
3. Handle the flexible cable carefully as it may break when subjected to strong force.
4. It is not possible to adjust the semi-fixed resistor that adjusts the laser power. Do not turn it

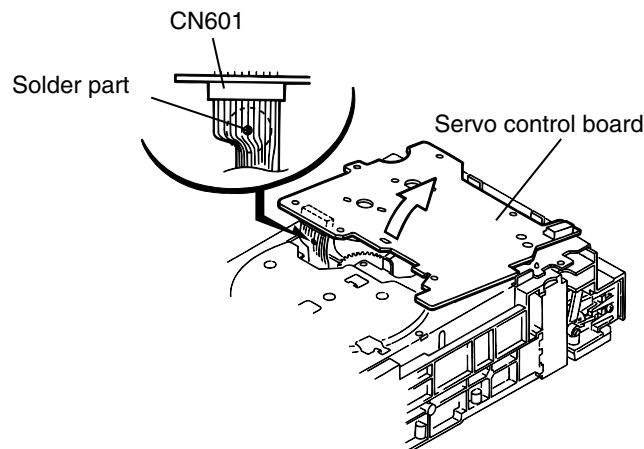

Disassembly method

<Main Body>

■ Removing the metal cover

(See Fig.1 and 2)

1. Remove the four screws **A** on the back of the body.
2. Remove the screw **B** on each side of the body.
3. Remove the rear part of the metal cover upward while pulling the lower part of both sides.

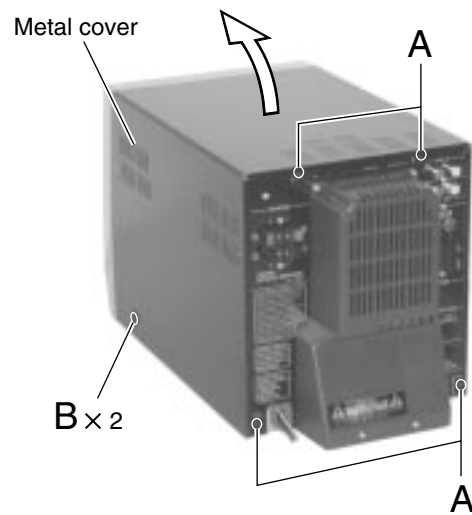

Fig.1

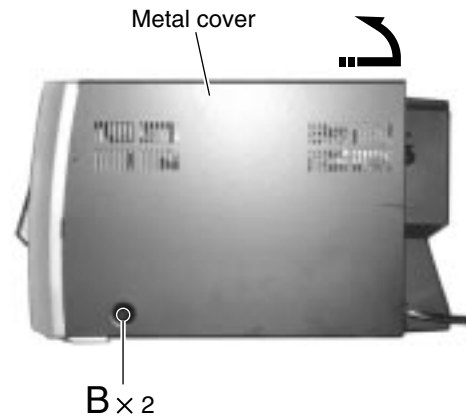

Fig.2

**■ Removing the front panel assembly
(See Fig.3 to 6)**

• Prior to performing the following procedure, remove the metal cover.

1. Disconnect the card wire from connector CN705, CN708, CN704 and CN712 on the main board.
2. Disconnect the wire from connector CN905 on the power board.

Remove the band from the Power board which sets the wire extending from connector CN905.

3. Remove the two screws **C** on each side of the body.
4. Remove the two screws **D** on the bottom of the body.
5. Disengage the joint **a** on the bottom and the two joints **b** on the lower side of the body using a screwdriver. Then remove the front panel assembly toward the front.

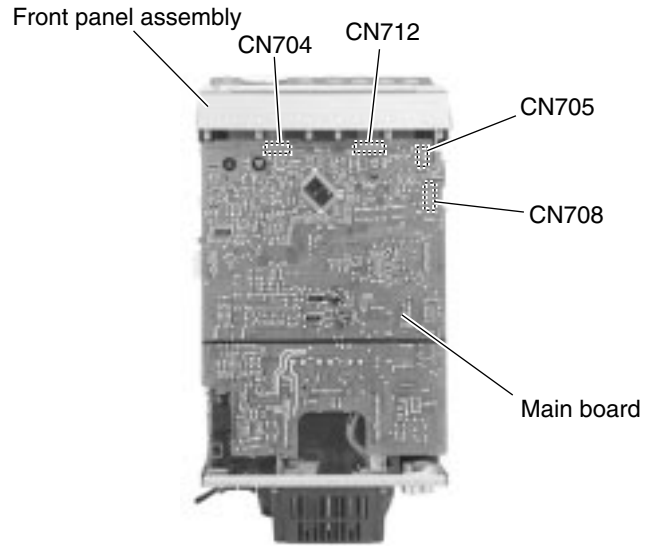

Fig.3

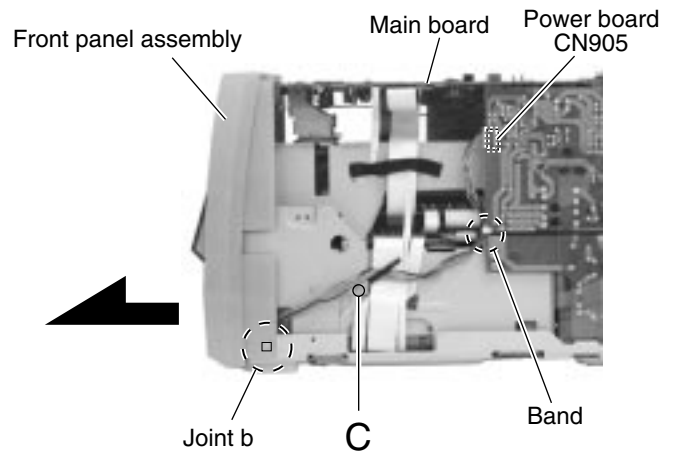

Fig.4

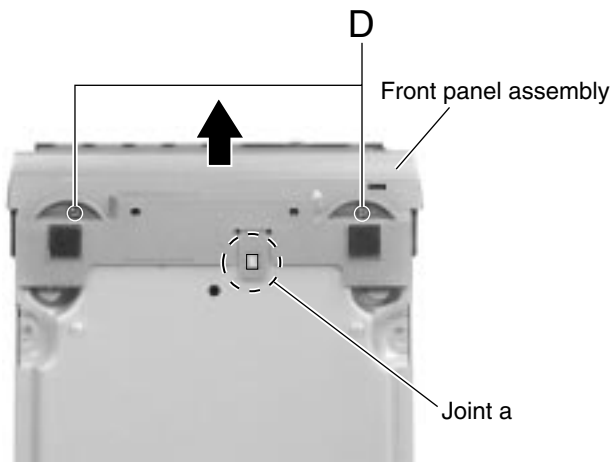

Fig.6

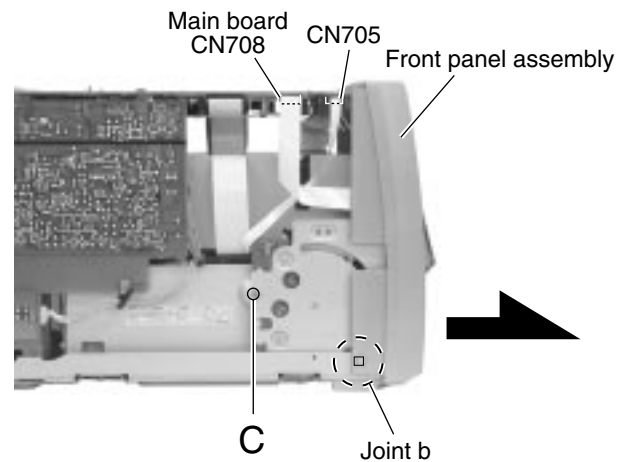

Fig.5

■ **Removing the main board**

(See Fig.7 and 8)

• Prior to performing the following procedure, remove the metal cover.

1. Disconnect the card wire from connector CN704, CN705, CN706, CN707, CN708, CN709 and CN712 on the main board on the upper side of body.
2. Remove the two screws **E** on the upper side of the body.
3. Disconnect connector CN701, CN702, CN703, CN710, CN711 on the main board from other boards respectively.

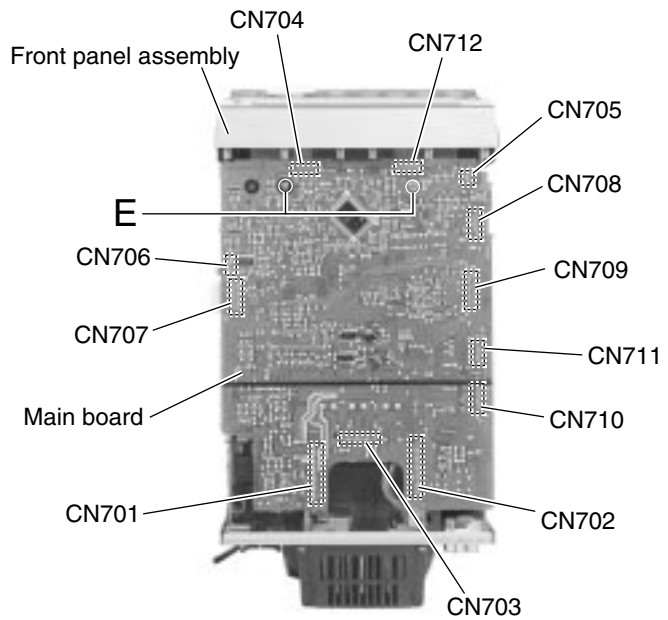

Fig.7

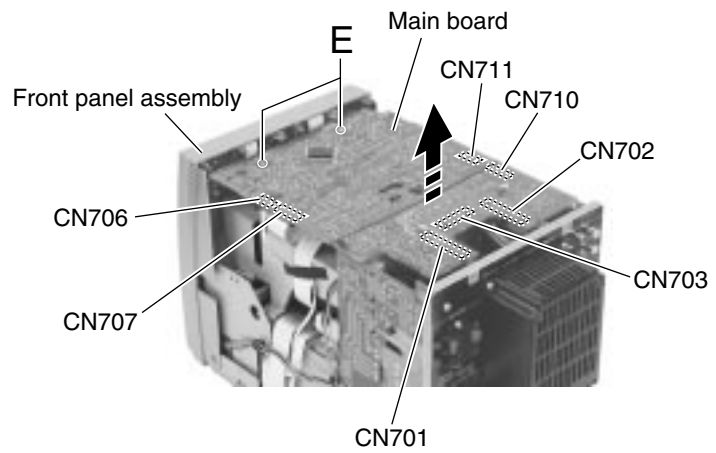

Fig.8

**■ Removing the rear cover / rear panel
(See Fig.9 to 12)**

· Prior to performing the following procedure, remove the metal cover.

1. Remove the four screws **F** on the back of the body, and press the two joints **c** inward to release.
2. Remove the thirteen screws **G** attaching the rear panel.
3. Disengage the two joints **d** in the lower part of the rear panel using a screwdriver.

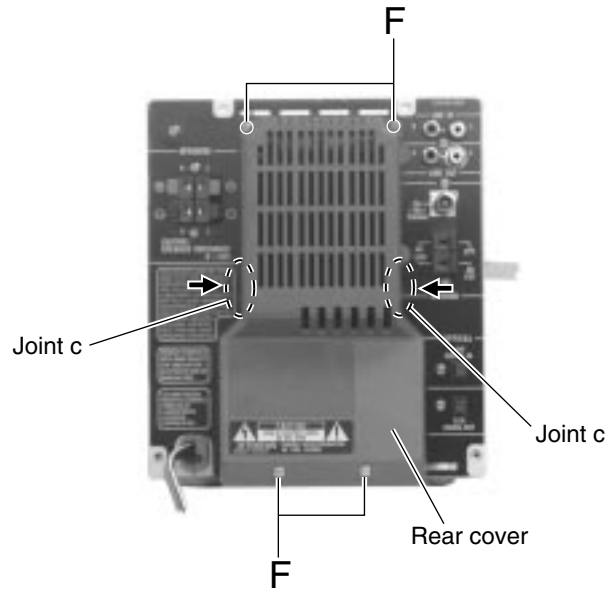

Fig.9

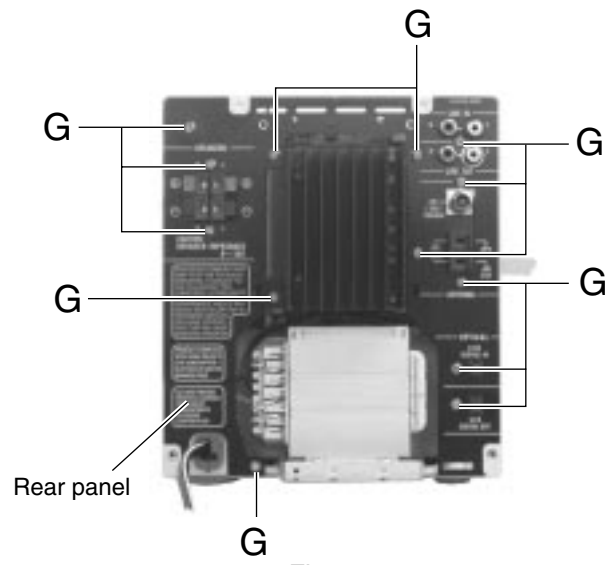

Fig.10

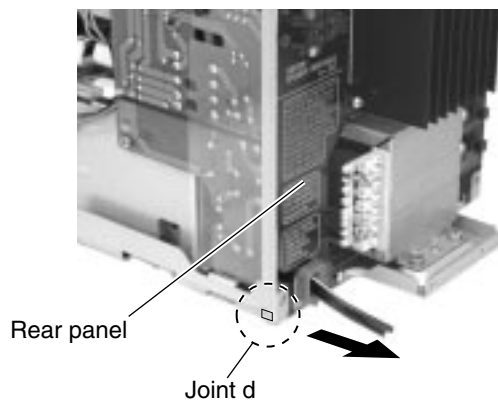

Fig.12

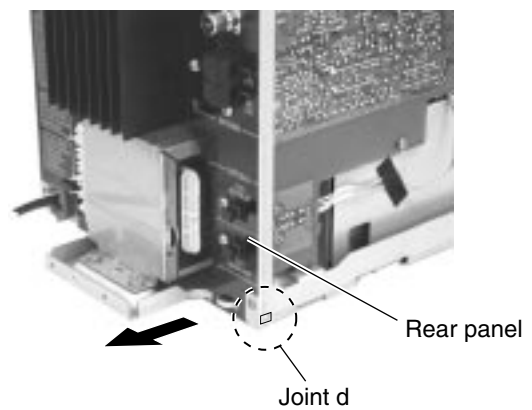

Fig.11

■ **Removing the tuner board (See Fig.13)**

• Prior to performing the following procedure, remove the metal cover, the main board and the rear panel.

1. Disconnect the wire from connector CN802 on the tuner board on the right side of the body.
2. Remove the screw **H** attaching the tuner board.
3. Move the tuner board upward and outward to disengage the tuner board from the base chassis at the joint **f**, and from the connector board at the joint **e**.

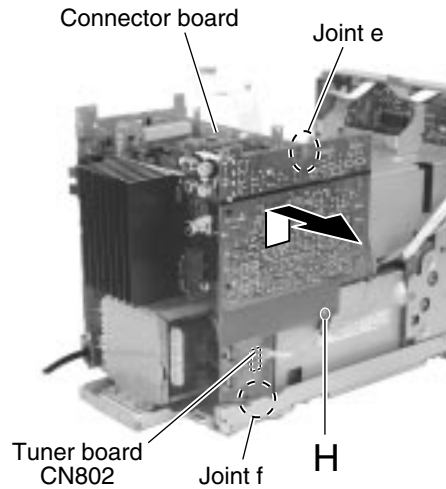

Fig.13

■ **Removing the power board (See Fig.14 and 15)**

• Prior to performing the following procedure, remove the metal cover, the main board and the rear panel.

1. Remove the two bands attaching the wire to the power board on the back of the body.
2. Disconnect the wire from connector CN901, CN904 and CN905 on the power board.
3. Remove the screw **I** on the left side of the body.
4. Disconnect connector CN902 and CN903 on the power board from the power board, and move the power board upward to disengage it from the base chassis at the joint **g**.

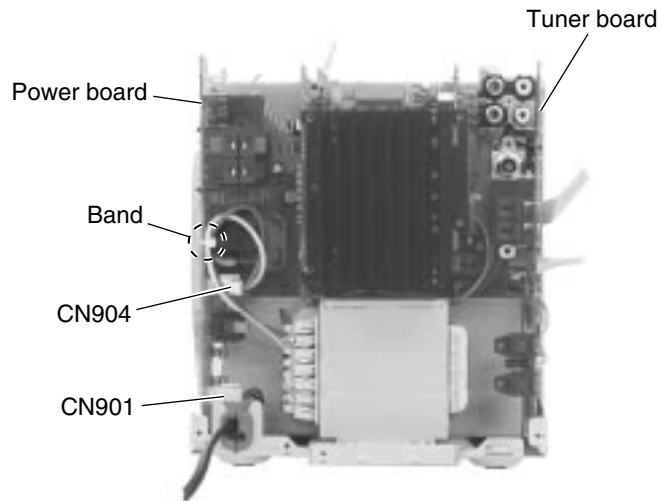

Fig.14

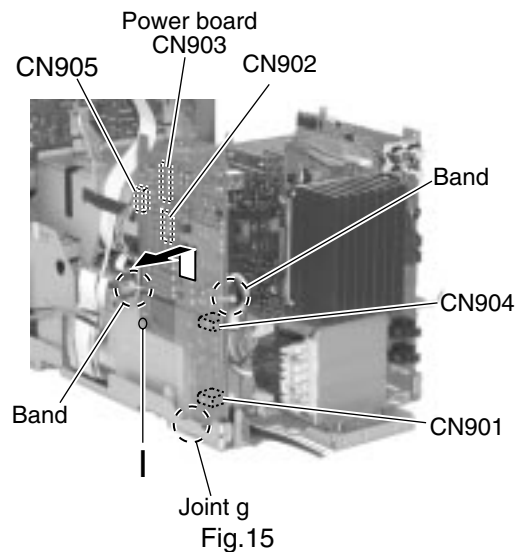
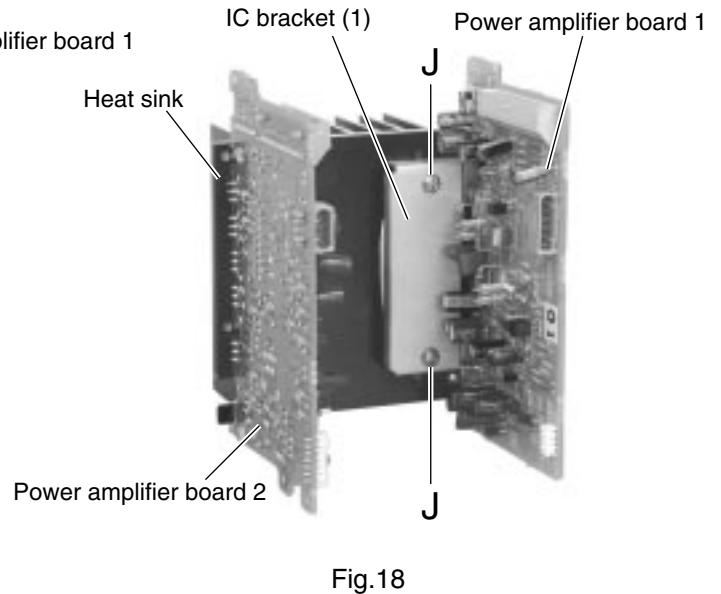
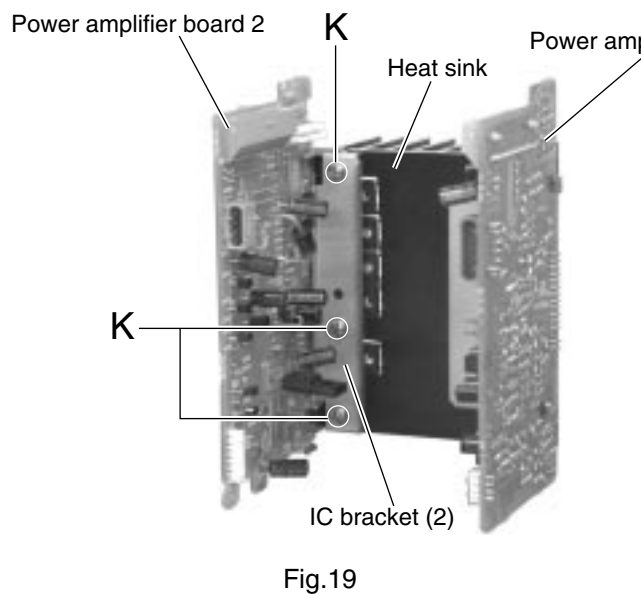
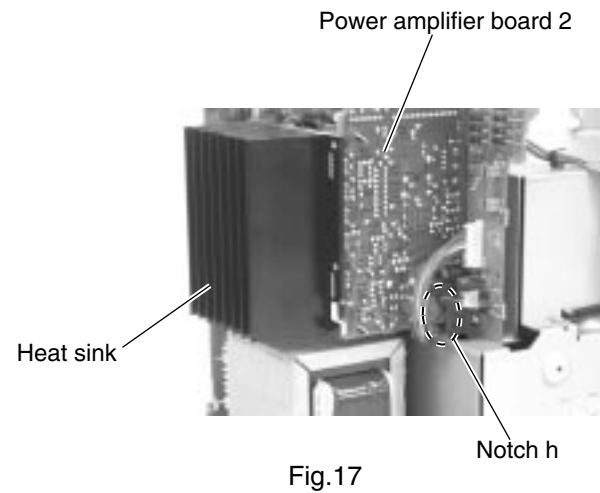
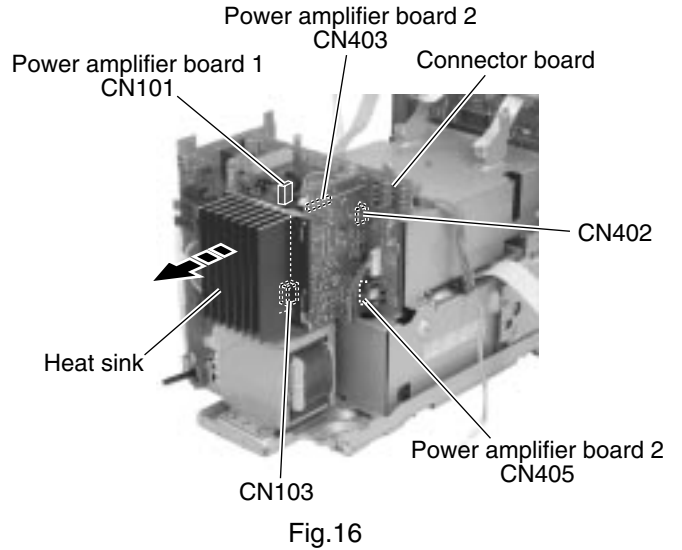

Fig.15

**■ Removing the power amplifier board 1 / power amplifier board 2 / heat sink
(See Fig.16 to 19)**

· Prior to performing the following procedure, remove the metal cover, the main board, the rear panel and the tuner board.

1. Disconnect the wire from connector CN403 on the power amplifier board 2.
2. As the wire extending from the fan, take it off the notch **h** in the lower part of the power amplifier board 2.
3. Disconnect connector CN101 and CN103 on the power amplifier board 1, and CN402 and CN405 on the power amplifier board 2 from the connector board respectively. The heat sink is still attached to the power amplifier board 1 and the power amplifier board 2.
4. Remove the two screws **J** attaching the IC bracket (1) on the back of the heat sink, and remove the power amplifier 1.
5. Remove the three screws **K** attaching the IC bracket (2) on the back of the heat sink, and remove the power amplifier 2.



■ Removing the fan (See Fig.20)

- Prior to performing the following procedure, remove the metal cover, the main board, the rear panel, the tuner board, the power amplifier board 1, the power amplifier board 2 and the heat sink.

REFERENCE: The fan is detachable without removing the CDR mechanism assembly.

1. Disconnect the wire from connector CN210 on the connector board.
2. Remove the two screws **L** attaching the fan.
3. Push down the clamp which settles the wire extending from the power transformer, in the direction of the arrow, and remove the fan backward.

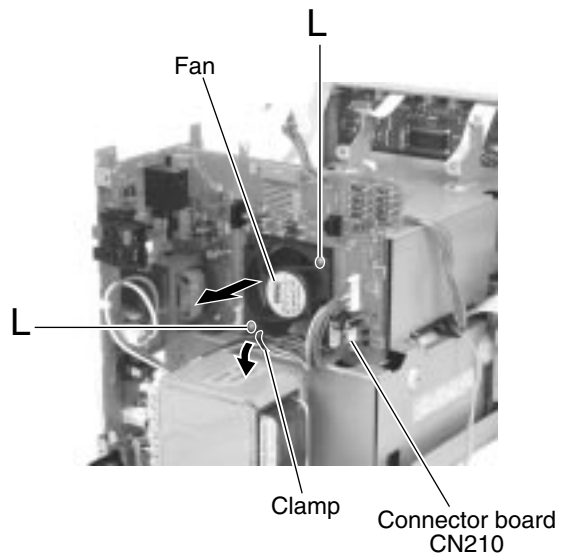

Fig.20

■ Removing the power board (See Fig.21)

- Prior to performing the following procedure, remove the metal cover, the main board, the rear panel, the tuner board, the power amplifier board 1, the power amplifier board 2 and the heat sink.

1. Disconnect the wire from connector CN203 and CN210 on the power board on the back of the body.
2. Remove the two screws **M** attaching the connector board.
3. Disconnect connector CN204 and CN207 on the connector board from the power board.

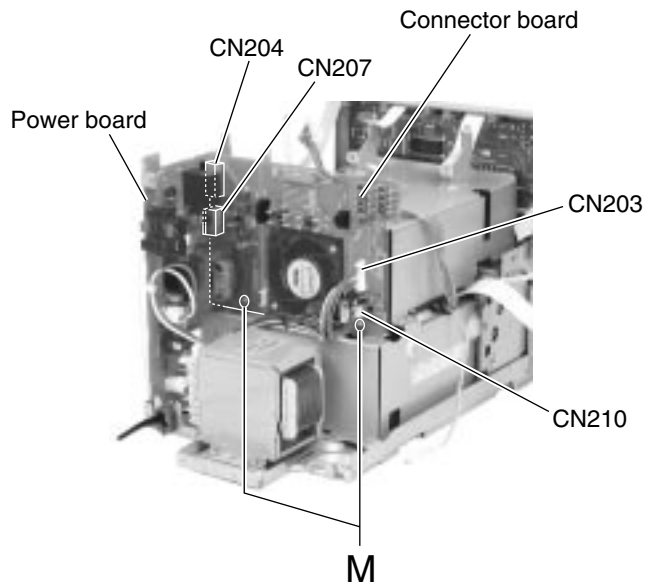

Fig.21

■ Removing the CDR mechanism cover / CDR mechanism assembly
(See Fig.22 to 27)

- Prior to performing the following procedure, remove the metal cover, the front panel assembly, the rear panel, the main board and the tuner board.

REFERENCE: When removing the CDR mechanism assembly only, refer to the next section.

REFERENCE: When removing the fan only, refer to "Removing the fan".

1. Remove the spacer settling the card wire on the right side of the body and release the wire from the clamp and the notch **i** of the power board on the upper side of the body. Disconnect the card wire from connector CN702 and CN703 on the CDR connection board.
2. Disconnect the wire from connector CN507 on the CD servo board.
3. Disconnect the wire from connector CN210 on the power board on the back of the body and release the wire from the notch **h** of the power amplifier board 2.
4. Remove the four screws **N** on the upper front side of the body and remove the CDR mechanism cover toward the front. The CDR mechanism assembly and the fan are also removed with the CDR mechanism cover.

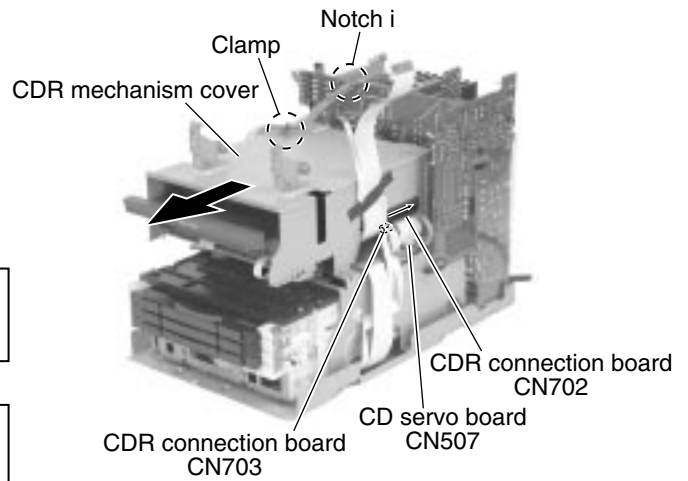

Fig.22

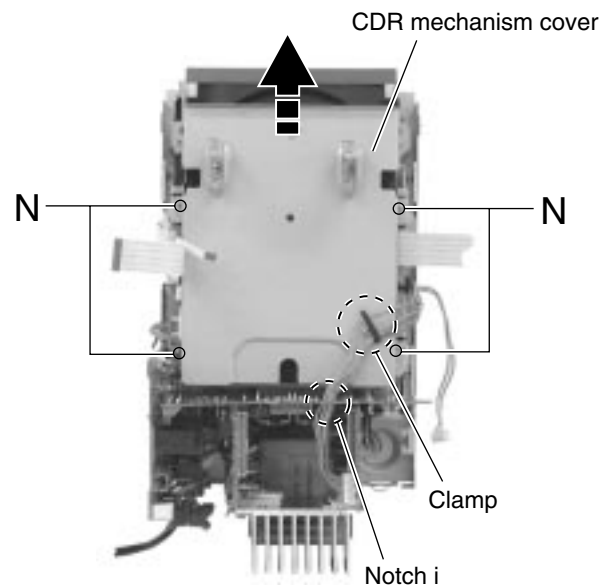

Fig.23

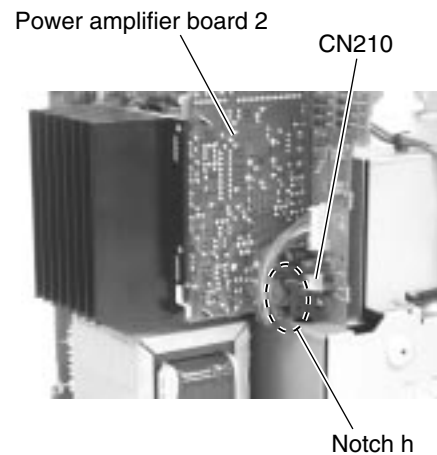

Fig.24

- Remove the three screws **○** attaching the CDR mechanism cover. Move the CDR mechanism assembly in the direction of the arrow, inside of the CDR mechanism cover, to disengage it from the three joint bosses marked **j**. Then remove the CDR mechanism assembly toward the front.

CAUTION: When reattaching the CDR mechanism assembly, let the wire extending from the rear of the CDR mechanism board through the back of the CDR mechanism cover as shown in Fig.26 (marked **k**).

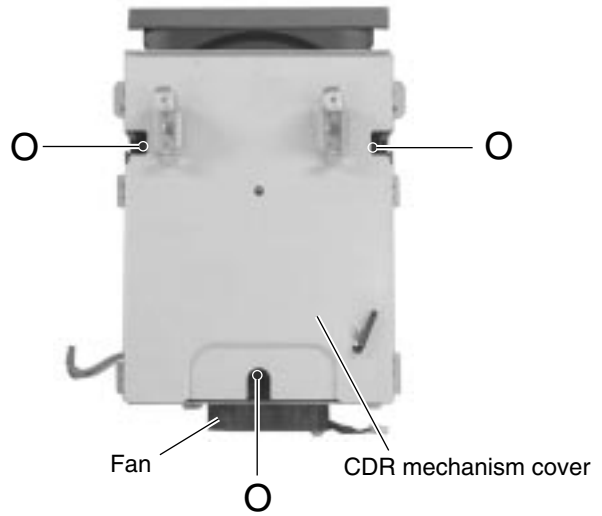

Fig.25

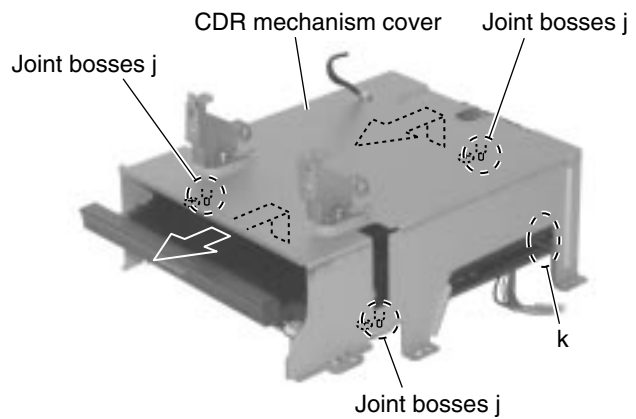

Fig.26

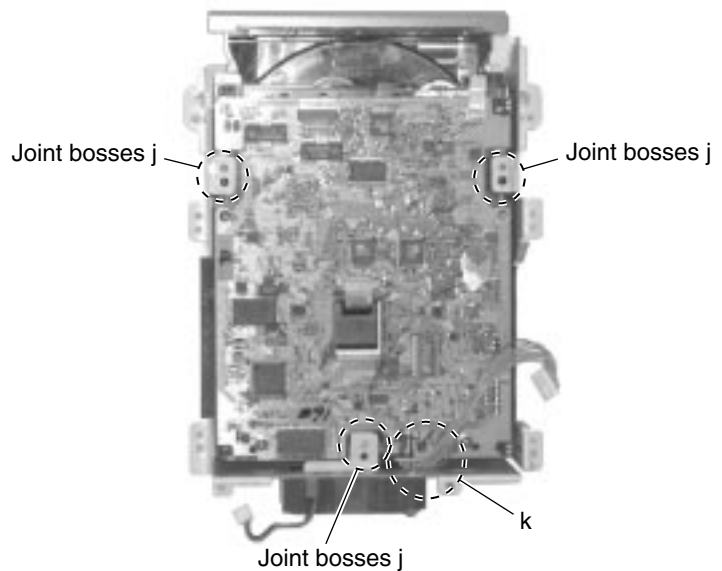

Fig.27

■ Removing the CDR mechanism assembly only (See Fig.28 and 29)

REFERENCE: The CDR mechanism assembly is detachable without removing the CDR mechanism cover.

· Prior to performing the following procedure, remove the metal cover, the front panel assembly and the main board.

1. Disconnect the card wire from connector CN702 and CN703 on the CDR connection board on the right side of the body.
2. Disconnect the wire from connector CN507 on the CD servo board.
3. Remove the three screws **O** on the upper side of the body.
4. Move the CDR mechanism assembly in the direction of the arrow, inside of the CDR mechanism cover, to disengage it from the three joint bosses marked **j**. Then pull out the CDR mechanism assembly toward the front (See Fig. 25 to 27).

CAUTION: When reattaching the CDR mechanism assembly, let the wire extending from the rear of the CDR mechanism board through the back of the CDR mechanism cover as shown in Fig.26 (marked **k**).

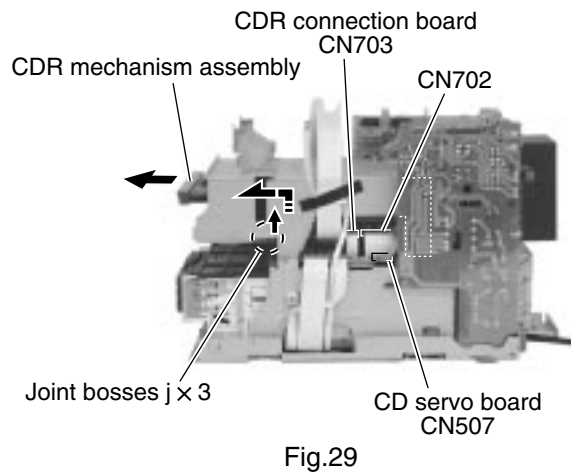
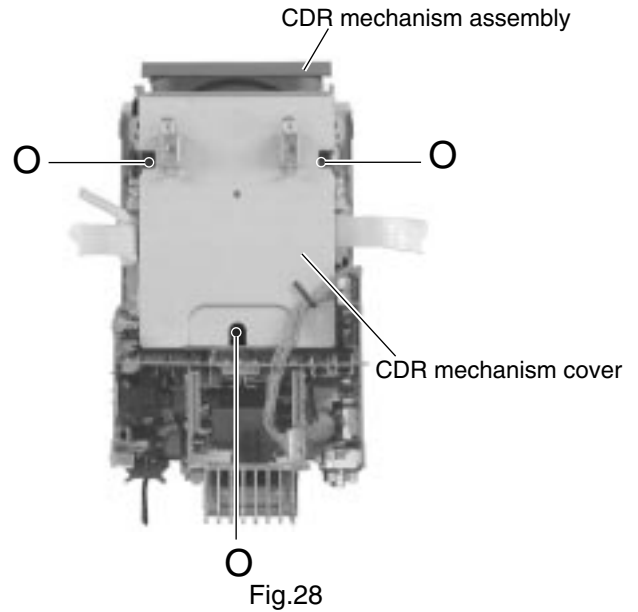

■ Removing the CD servo board (See Fig.30)

· Prior to performing the following procedure, remove the metal cover, the front panel assembly, the main board, the rear panel, the tuner board and the CDR mechanism cover.

1. Disconnect the card wire from connector CN504 and CN505 on the CD servo board on the upper side of the body.
2. Disconnect the wire from connector CN403 on the power board.
3. Remove the two screws **P** and move the CD servo board in the direction of the arrow to release the two joints **I**.

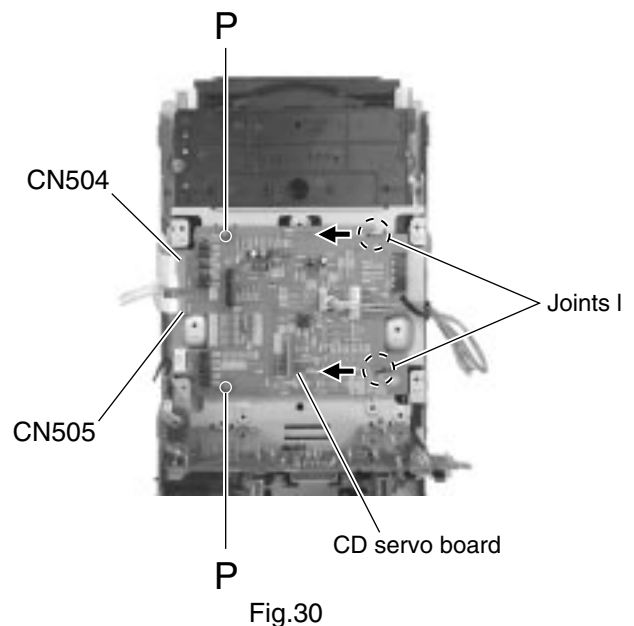

■ **Removing the CD changer mechanism assembly (See Fig.31 to 33)**

REFERENCE: The CD changer mechanism assembly is detachable without removing the CDR mechanism cover and the CDR mechanism assembly.

• Prior to performing the following procedure, remove the metal cover, the front panel assembly and the main board.

1. Disconnect the card wire from connector CN606, CN608, CN651 on the CD changer mechanism board on the right side of the body.
2. Remove the four screws **Q** attaching the CD changer mechanism assembly on the upper side of the body.
3. Move the CD changer mechanism assembly in the direction of the arrow, inside of the CD changer mechanism cover, and pull out it toward the front while raising it slightly.

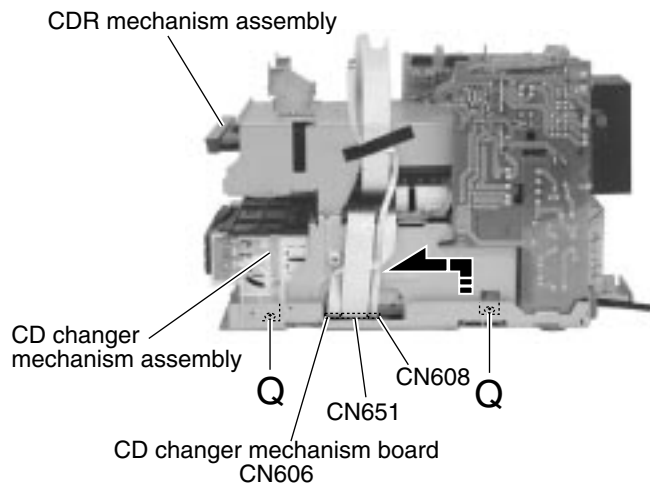

Fig.31

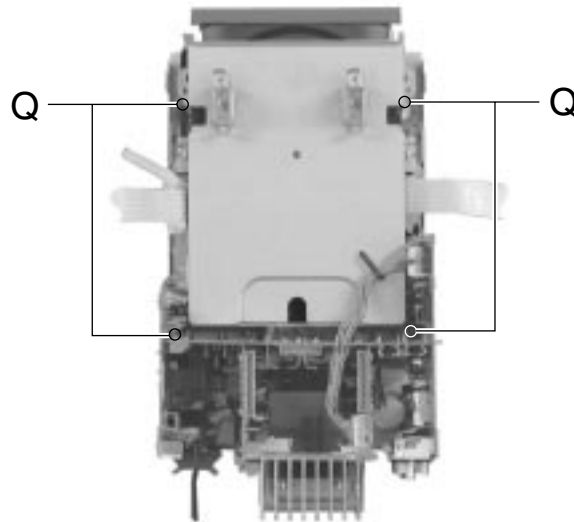

Fig.32

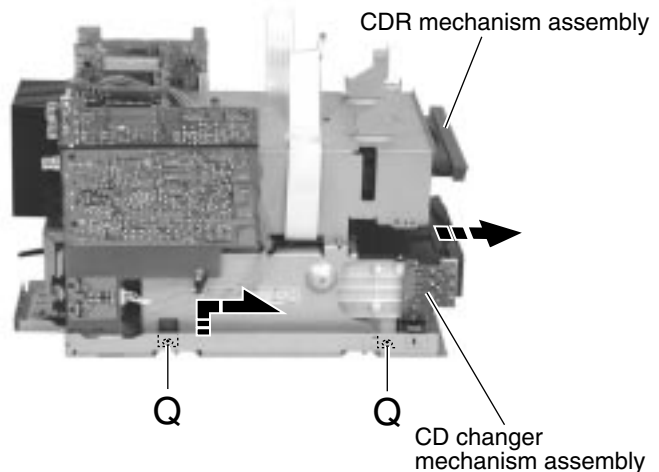

Fig.33

■ Removing the power transformer assembly (See Fig.34 and 35)

- Prior to performing the following procedure, remove the metal cover, the main board, the rear panel, the tuner board, the power amplifier board 1, the power board and the heat sink.
1. Remove the band setting the wire on the power board on the back of the body and disconnect the wire from connector CN904.
 2. Disconnect the wire from connector CN203 on the connector board.
 3. Remove the four screws **R** on the upper side of the body, and remove the power transformer assembly from under the heat sink backward.

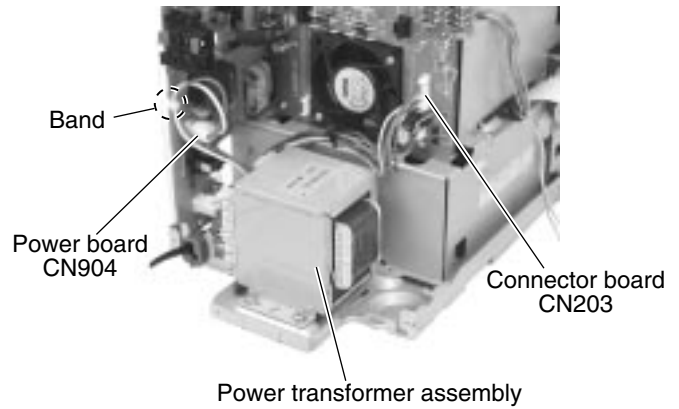

Fig.34

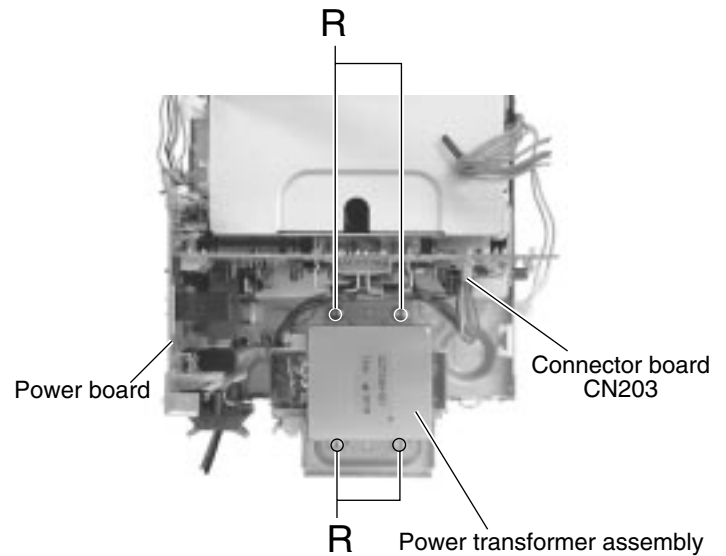

Fig.35

<Front panel assembly section>

- Prior to performing the following procedures, remove the metal cover and the front panel assembly.

■ Removing the LCD board (See Fig.36)

1. Remove the four screws **S** on the back of the front panel assembly.

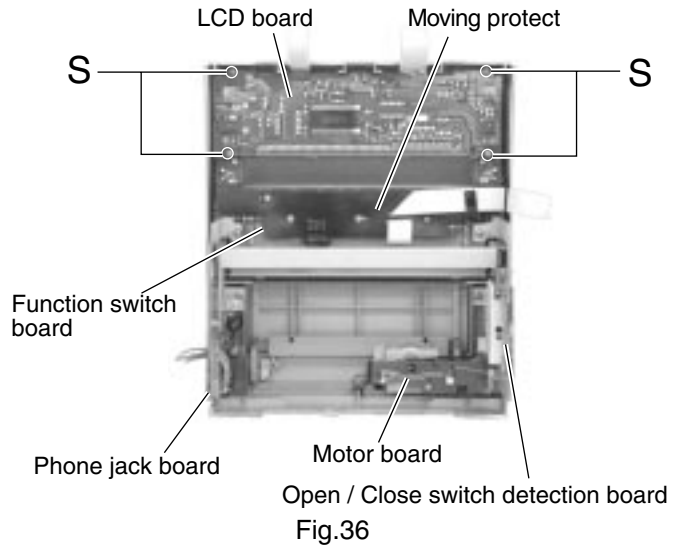

■ Removing the function switch board (See Fig.37)

1. Remove the seven screws **T**.
2. Disconnect the card wire from connector CN671 and CN672 on the function switch board.

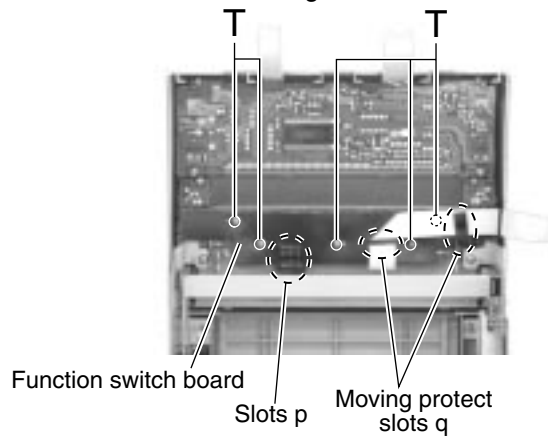

Fig.37

REFERENCE: To reattach the function switch board (See Fig.37 to 40)

- Connect the card wire to connector CN671 and CN672 before reassembling.
- Bend the card wire extending from connector CN671 as shown in Fig.38 and 39, and pass it through the two slots **p** of the moving protect to fix.
- Bend the card wire extending from connector CN672 as shown in Fig.40. Pass it through the two slots **q** of the moving protect and attach to the front panel using the spacer.

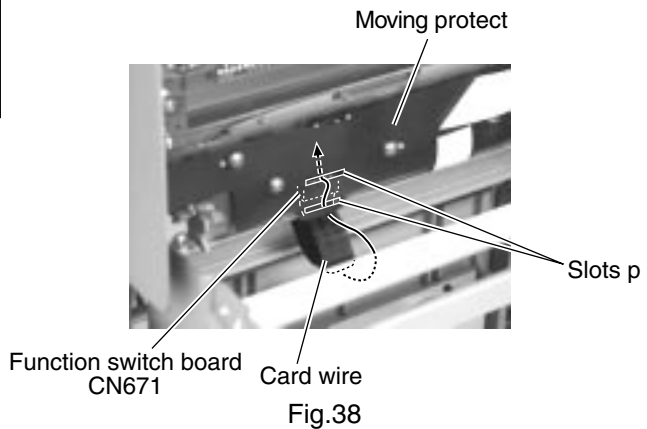

Fig.38

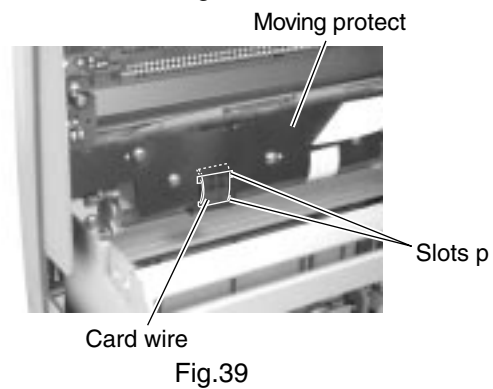

Fig.39

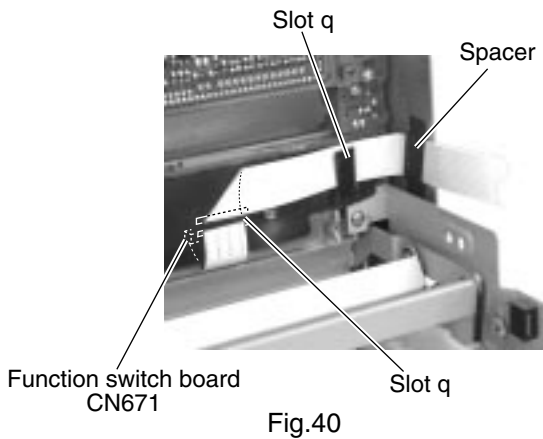
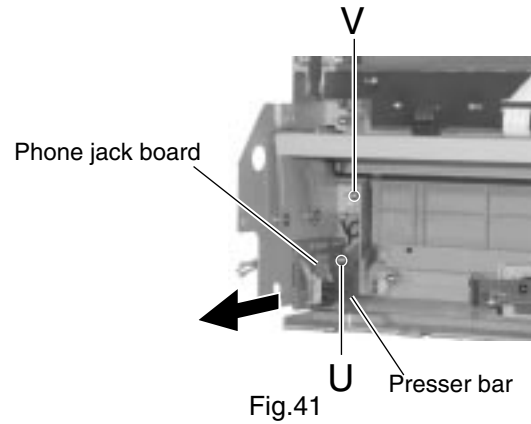

Fig.40

**■ Removing the phone jack board
(See Fig.41)**

1. Remove the screw **U** attaching the presser bar.
2. Remove the screw **V** attaching the ground terminal extending from the phone jack board.



■ Removing the motor board (See Fig.42)

1. Disconnect the wire from connector CN582 on the Open / Close switch detection board.
2. Disconnect the wire from connector CN583 on the motor board.
3. Remove the screw **W**.

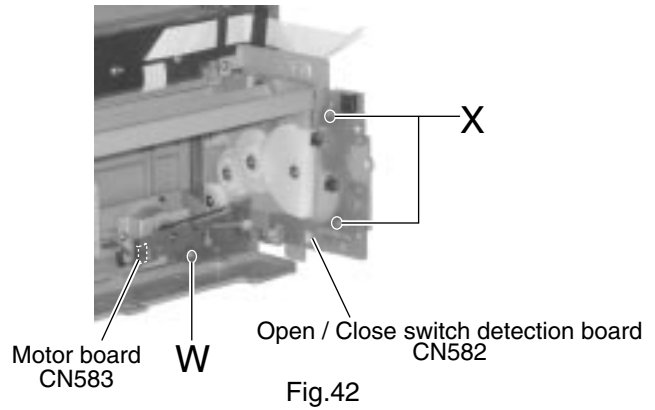

■ Removing the Open / Close switch detection board (See Fig.42)

1. Disconnect the wire from connector CN582 on the Open / Close switch detection board.
2. Remove the two screws **X**.

**■ Removing the door motor
(See Fig.43 and 44)**

- Prior to performing the following procedure, remove the motor board.
1. Remove the belt from the door motor.
 2. Remove the screw **Y** attaching the door motor bracket.
 3. Remove the two screws **Z** attaching the door motor.

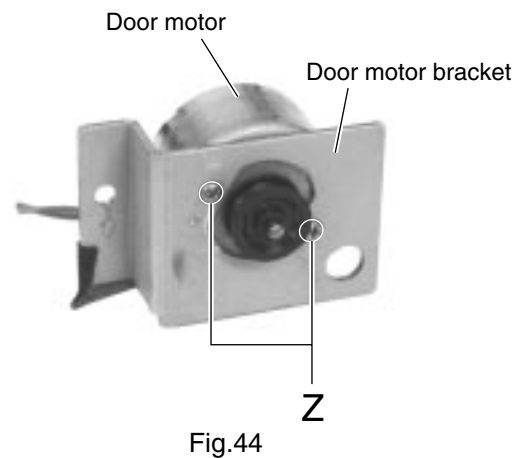
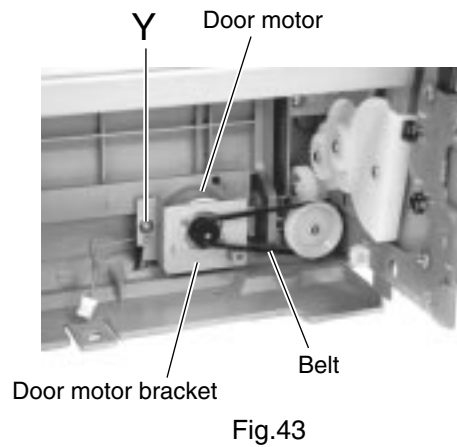

■ Removing the control board
(See Fig.42 to 46)

• Prior to performing the following procedure, remove the function switch board and the motor board / belt.

1. Remove the belt and move the control panel assembly toward the front by turning the pulley (1) until it stops.
2. Push the moving cover in the direction of the arrow to disengage the two joints **m** at the bottom of the control panel assembly. Move the moving cover inward to disengage the left and right joints **n**. Remove the control panel assembly.
3. Move each joint **o** as shown in the figure and release toward the front.

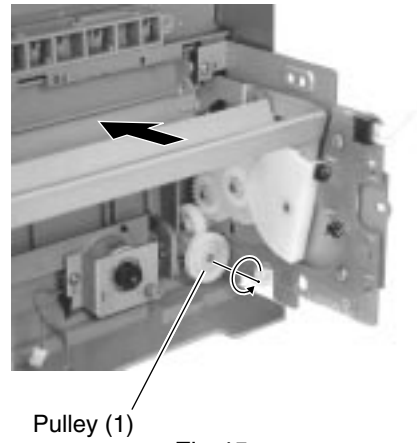

Fig.45

CAUTION: Do not lose the two collars attached to each shaft of the joints **o**.

4. Remove the four screws **Z'** attaching the control board.

REFERENCE: To reattach the control panel assembly, pass the card wire extending from the control board through the slot **r** of the control panel as shown in Fig.50.

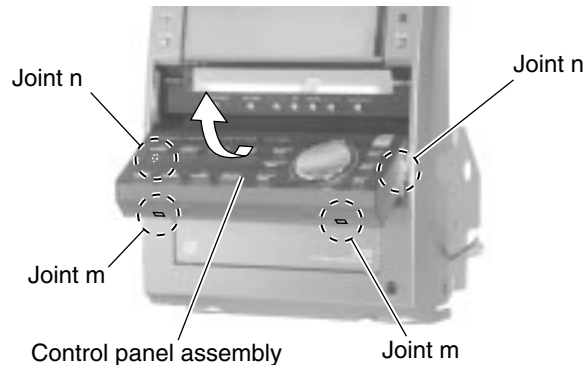

Fig.46

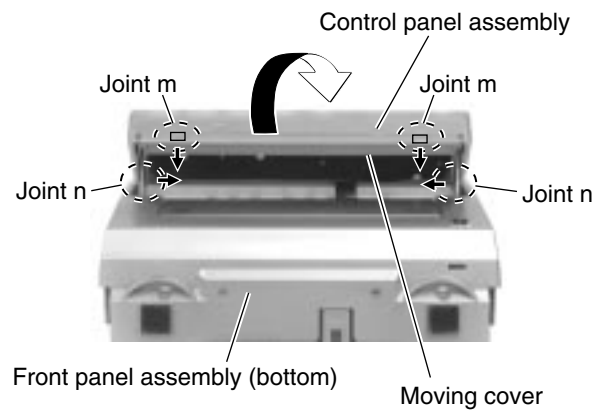

Fig.47

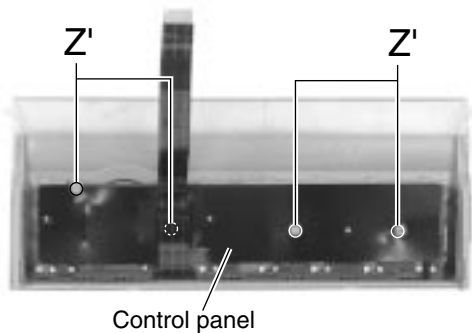

Fig.49

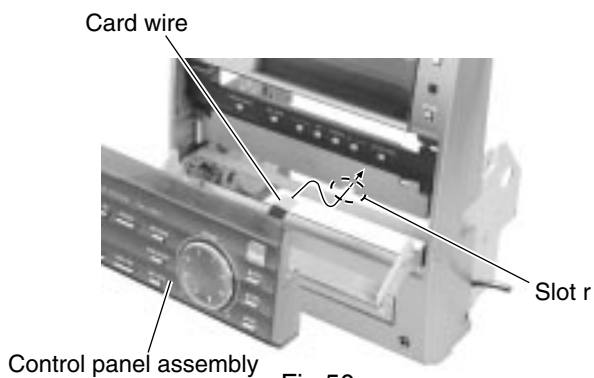

Fig.50

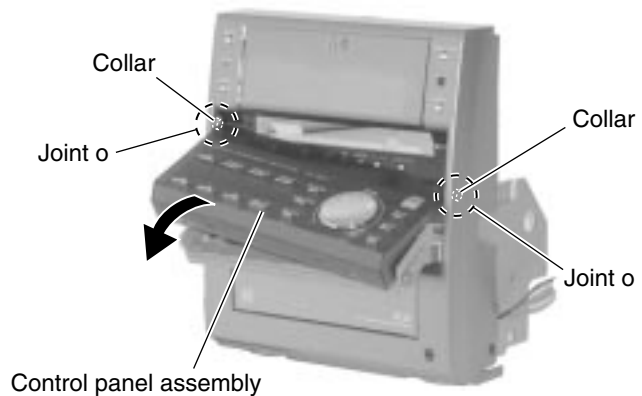

Fig.48

<Changer mechanism assembly>

■ Removing the servo control board
(See Fig.1 to 4)

ATTENTION: Make sure the sub chassis unit is locating at the lowest position. If not, perform the following procedure from 1 to 3.

1. Insert a screwdriver into the sub chassis slot on the back of the body and push the slider (R) toward the front.
2. From the top of the body, slide the hook and the slider (R) forward until they stop.
3. From the right side of the body, slide the slide cam (L) backward until it stops. The sub chassis unit will move to the lowest position.
4. From the bottom of the body, unsolder each soldered part **a** and **b** of the motors on the servo control board.
5. Remove the five screws **A** attaching the servo control board.
6. Disconnect connector CN610 on the servo control board from the tray select switch board to suspend the servo control board tentatively. Solder the part **c** of the flexible wire connected to connector CN601 on the underside of the servo control board.
7. Disconnect the flexible wire from connector CN601 and remove the servo control board from the body.

ATTENTION: In case of disconnecting the flexible wire without soldering, the CD pick up may be damaged.

ATTENTION: When reassembling, make sure the cam switch boss of the servo control board is fitted to the slot **p** of the control cam on the bottom of the body (Refer to Fig.3-1).

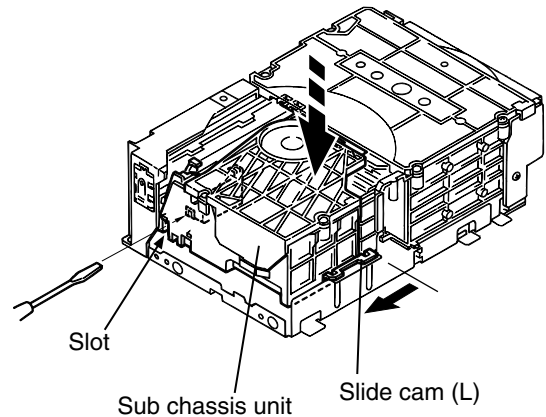

Fig.1

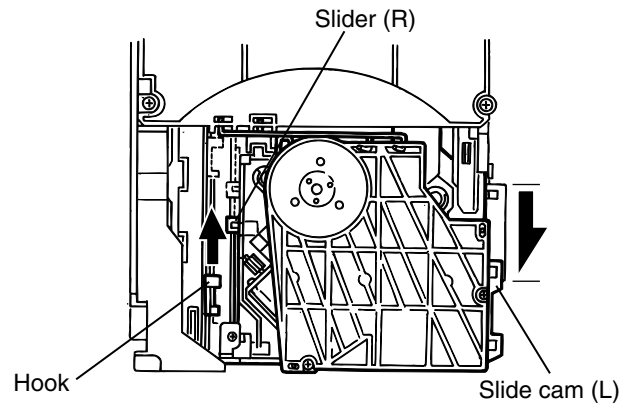

Fig.2

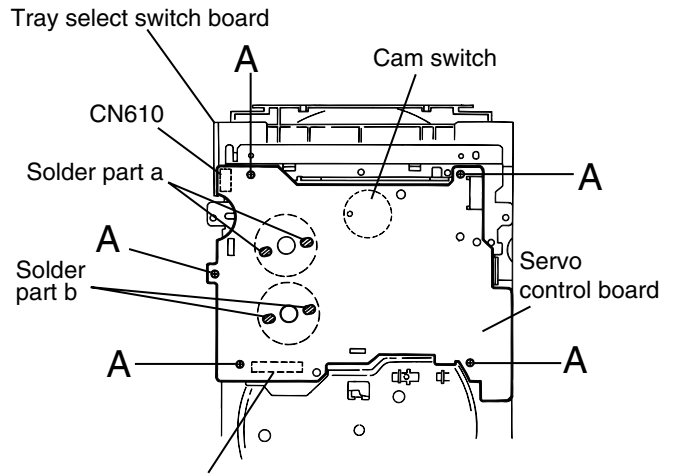

Fig.3-1

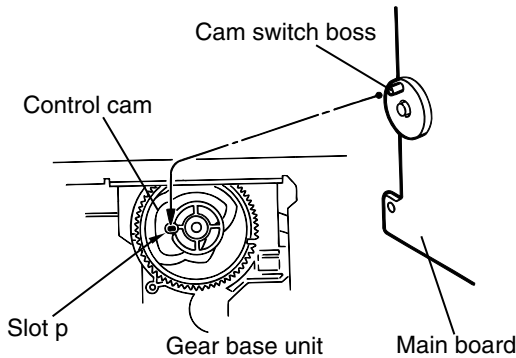

Fig.3-2

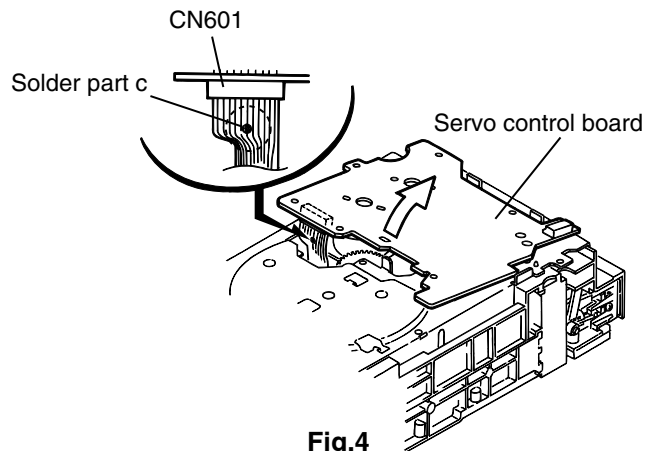

Fig.4

■ Removing the tray unit (See Fig.5 to 8)

※ The tray unit can be removed despite the position of the sub chassis unit, but the lowest position is recommended to expedite the work.

1. Remove the four screws **B** attaching the top cover on the top of the body.
2. Remove the top cover with the two rods attached to the top cover and the clamper base unit.
3. Pull the lock lever of the return spring on the right side of the body to eject the tray unit.
4. From the top of the body, release the tray from the joint hook marked **d** (Push the tray toward the front).
5. Release the stoppers on both sides in the direction of the arrow and pull out the tray unit from the body.

ATTENTION: Pull out the tray unit from the top tray 3 in sequence.

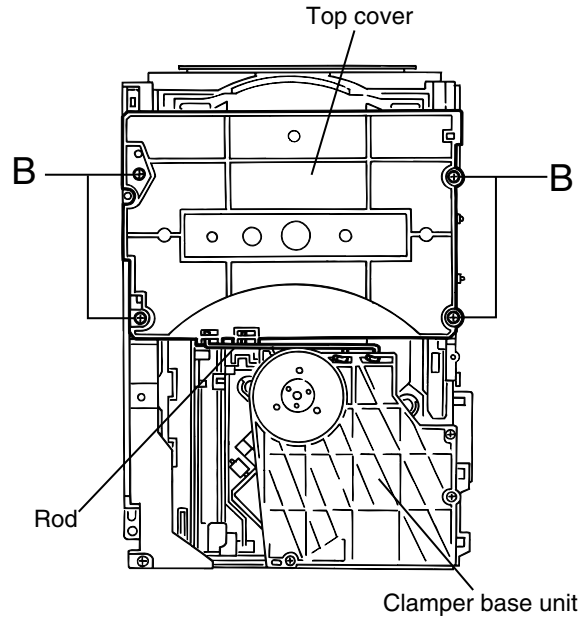

Fig.5

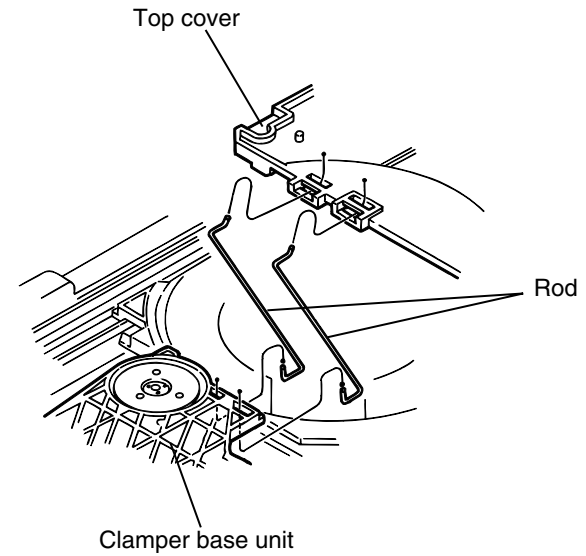

Fig.6

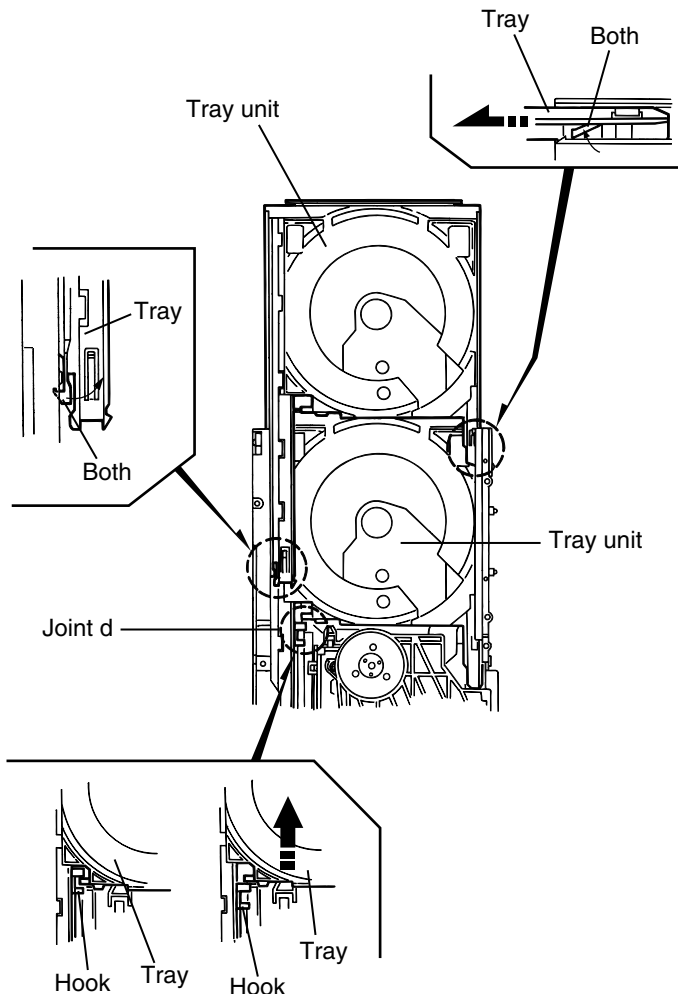

Fig.8

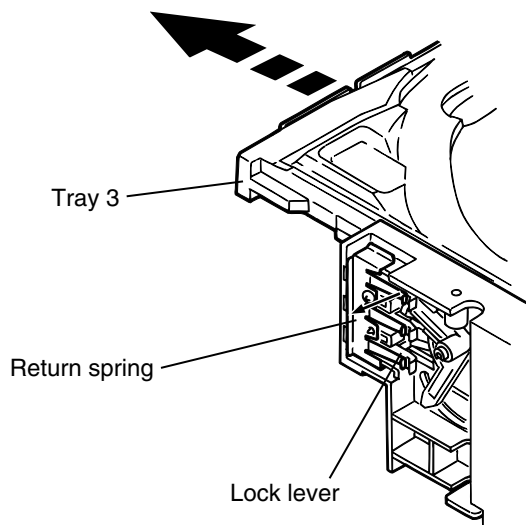

Fig.7

■ Removing the side unit (L) and (R)
(See Fig.9-1 to 9-5)

• Prior to performing the following procedures, remove the servo control board, the top cover and the tray unit.

1. Remove the two screws **C** attaching the side unit (L).
2. Slide and remove the side unit (L) toward the front while releasing the two joints **e** and the joint **f** with the chassis unit.
3. Slide the slide cam (L) toward the front until it stops to place the sub chassis unit at the top position.

ATTENTION: The side unit (R) can be removed when the sub chassis unit is located at the top position.

4. Turn the hook gear counterclockwise to move the slide hook and the slider (R) backward until they stop.
5. Remove the three screws **D** attaching the side unit (R). Raise the side unit (R) upward and release the joint **g** with the chassis unit and the boss from the select arm marked **h**. Then remove the side unit (R) from the body.

ATTENTION: When reassembling, make sure the boss is fitted to the select arm marked **h**.

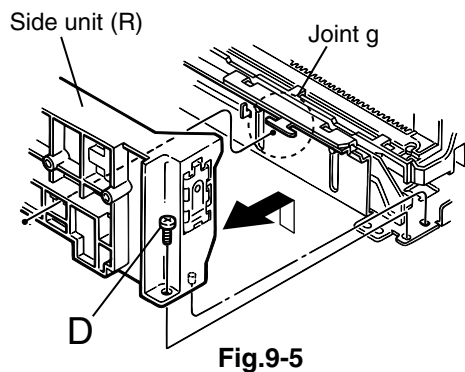
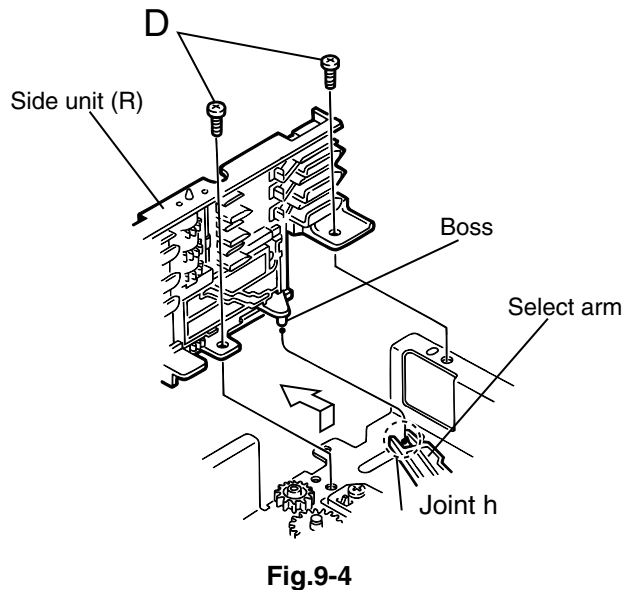
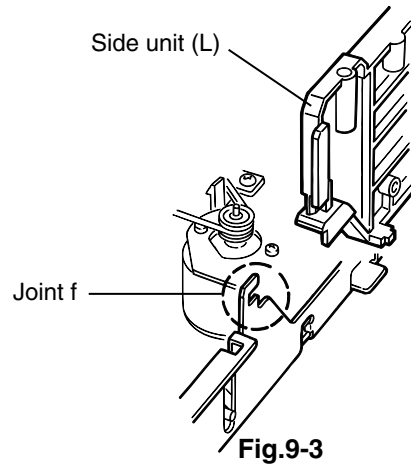
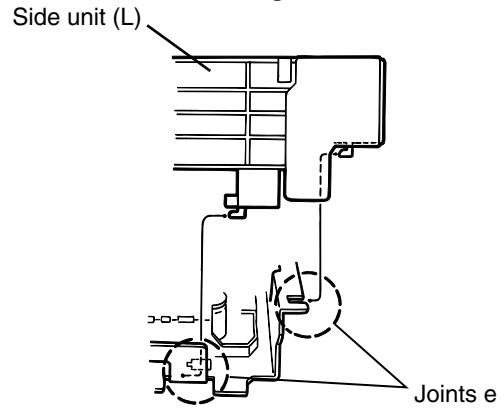
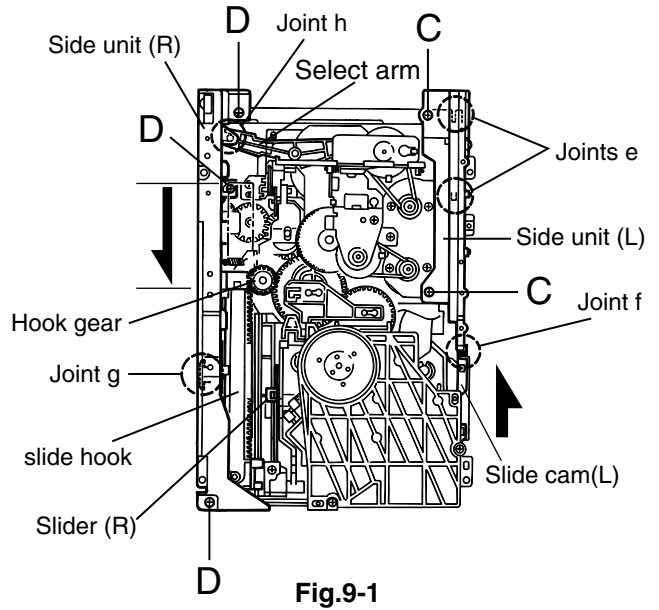

■ Removing the sub chassis unit
(See Fig.10 to 12)

• Prior to performing the following procedures, remove the servo control board, the top cover, the tray unit, the side unit (L) and the side unit (R).

1. Turn the hook gear counterclockwise to move the slide hook and the slider (R) backward until they stop.
2. Slide the slide cam (L) and the slide cam (R) in the direction of the arrow until they stop.

(The notches of each slide cam are fitted to the pins on both sides of the sub chassis unit.)

3. Detach the sub chassis unit upward.

ATTENTION: When reassembling, turn the hook gear of the chassis unit counterclockwise until it stops and slide the slide hook and the slider (R) of the sub chassis unit backward until they stop.

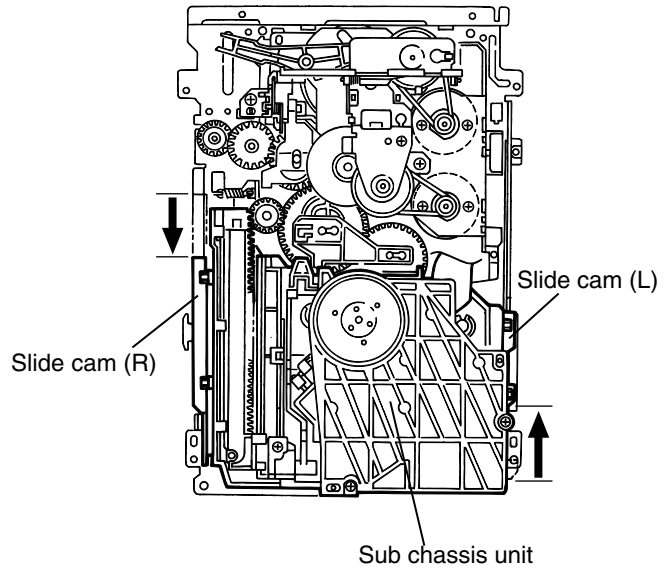

Fig.10

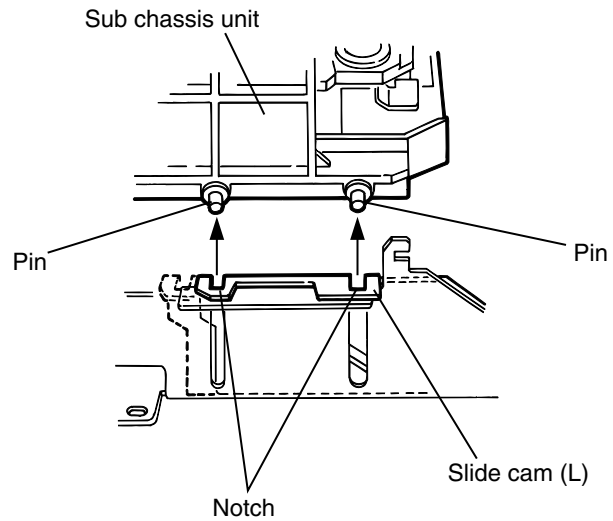

Fig.11

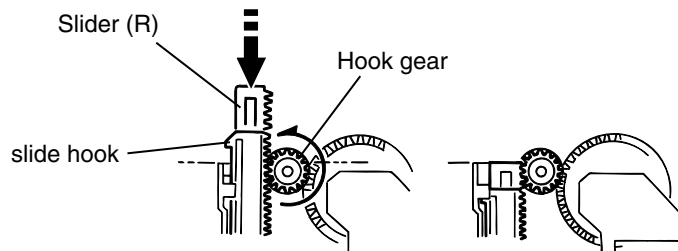

Fig.12

■ Removing the flap base unit and the gear base unit (See Fig.13 and 14)

• Prior to performing the following procedures, remove the servo control board, the top cover, the tray unit, the side unit (L) and the side unit (R).

1. Remove the screw **E** attaching the flap base unit. Release the joint tabs **i** and **j**, then remove the flap base unit from the body.
2. Remove the belts from the two pulleys on the gear base unit.
3. Remove the three screws **F** and remove the gear base unit from the body.

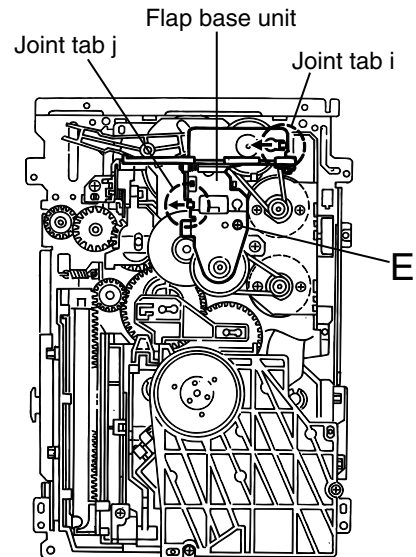

Fig.13

■ Removing the motors (See Fig.15)

• Prior to performing the following procedure, remove the main board.

1. Remove the belts from the two pulleys.
2. Remove the four screws **G** and detach each motor from the body.

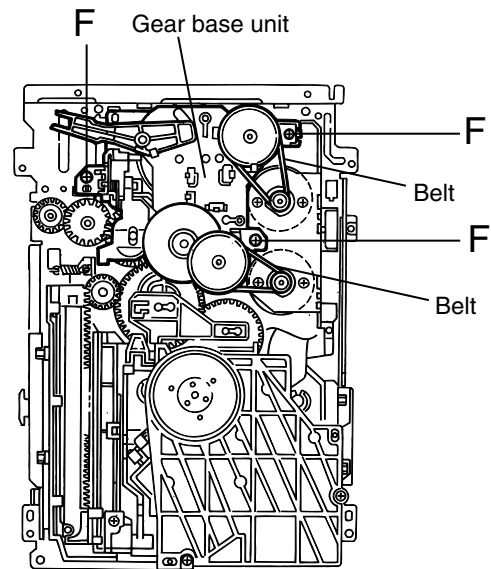

Fig.14

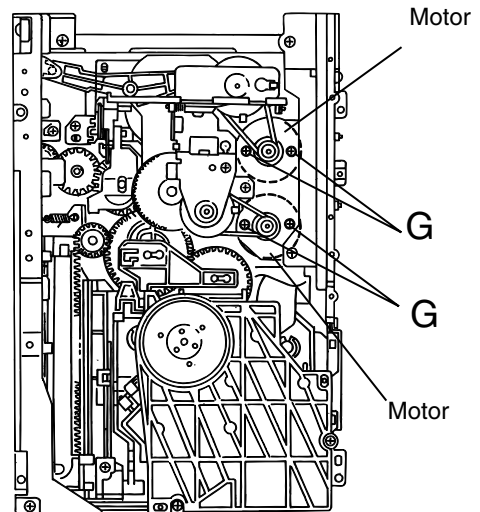

Fig.15

■ **Removing the pickup (See Fig.16 to 20)**

1. From the top of the body, remove the three screws **H** attaching the clamber base unit.
2. Remove the clamber base unit with the two rods attached to the clamber base unit and the top cover.
3. Turn the screw shaft gear marked **k** in the direction of the arrow to move the pickup unit.
4. Remove the screw **I** attaching the shaft holder.
5. Move the screw shaft in the direction of the arrow and release it from the joint **I**. Then release it from the joint **m** with the pickup holder. Detach the pickup with the screw shaft.
6. Solder the part **n** of the flexible board on the underside of the pickup. After soldering, disconnect the flexible wire connected to the pickup (In case of disconnecting the flexible wire without soldering, it may cause damage to the CD pickup).
7. Remove the two screws **J** attaching the rack arm to the pickup unit.
8. Pull out the screw shaft from the pickup.

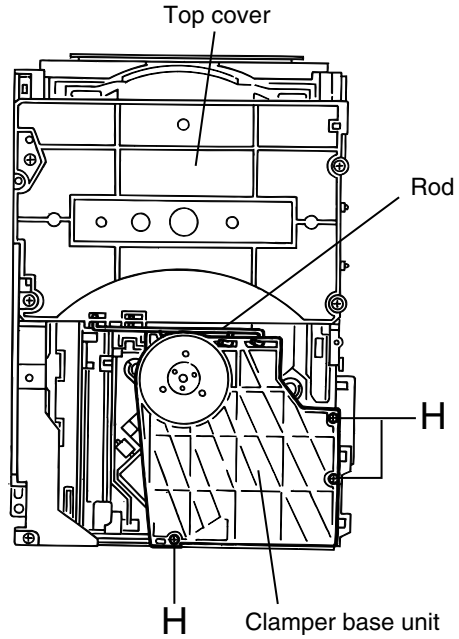

Fig.16

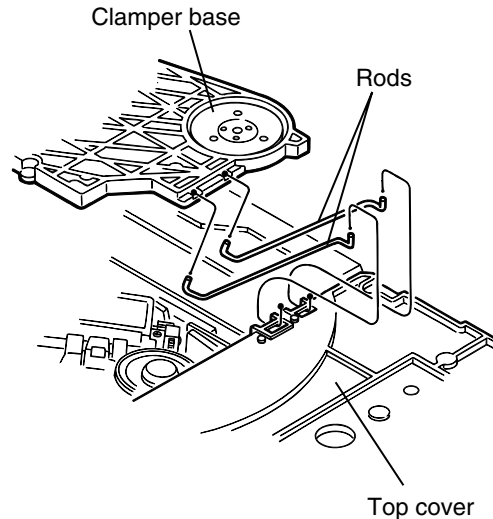

Fig.17

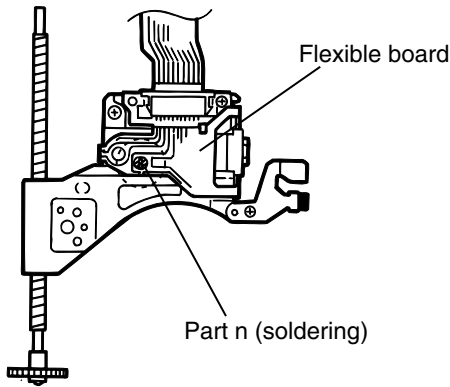

Fig.19

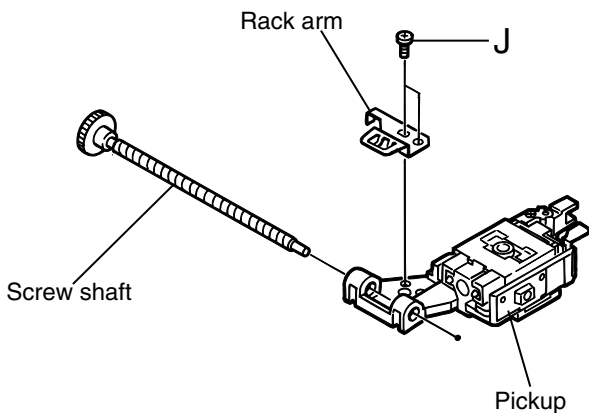

Fig.20

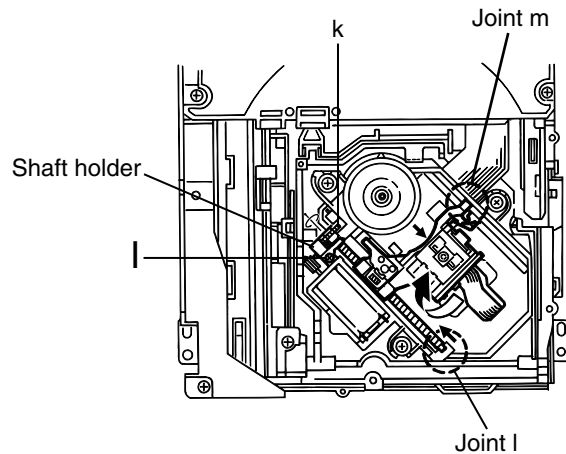

Fig.18

■Removing the traverse mechanism assembly (See Fig.21)

• Prior to performing the following procedure, remove the servo control board and the clamper base unit.

1. Remove the three screws **K** attaching the traverse mechanism assembly.
2. Detach the rear part of the traverse mechanism assembly upward to release the joint **o** with the sub chassis unit. Then remove the assembly from the body.

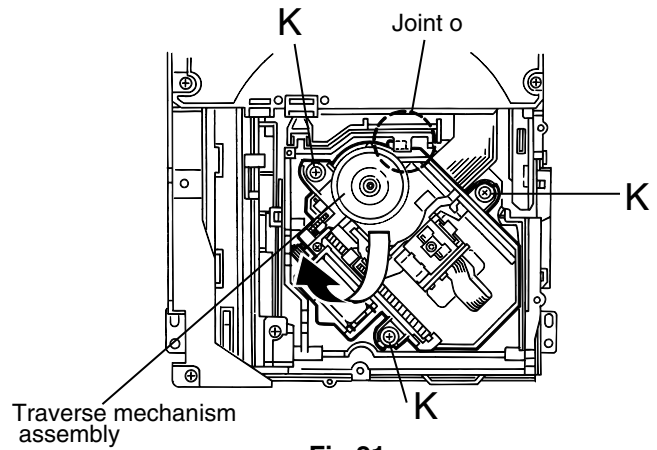

Fig.21

■Removing the feed motor (See Fig.22)

• Prior to performing the following procedure, remove the traverse mechanism assembly.

1. Remove the screw **L** attaching the feed motor.

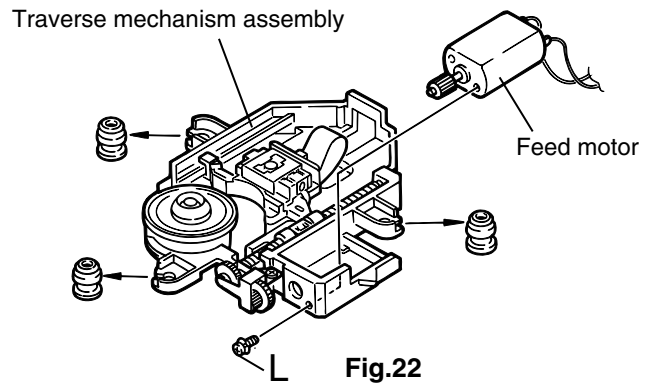

Fig.22

■Removing the tray select switch board (See Fig.5,6 and 23)

1. Remove the four screws **B** attaching the top cover on the top of the body.
2. Remove the top cover with the two rods attached to the top cover and the clamper base unit.
3. Remove the screw **M** on the right side of the body.

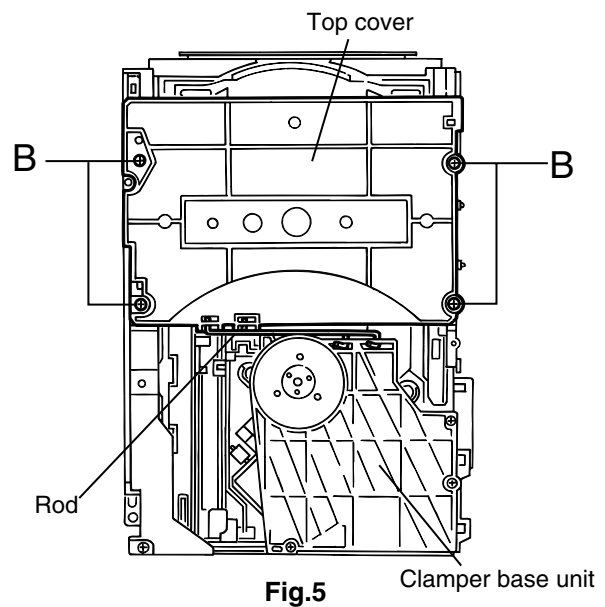

Fig.5

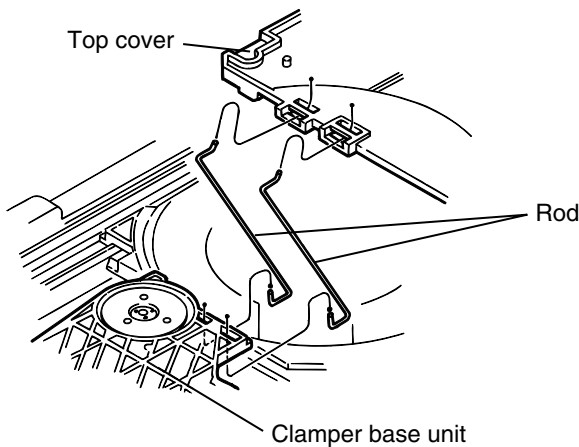

Fig.6

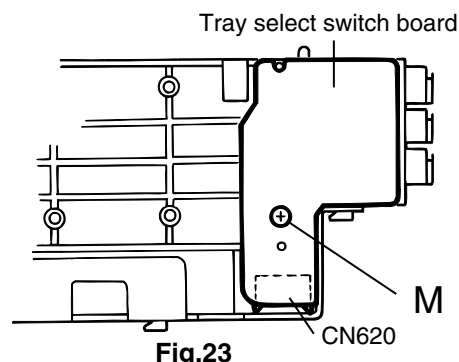

Fig.23

Adjustment method

Measurement instruments required for adjustment

1. Low frequency oscillator,
This oscillator should have a capacity to output 0dBs to 600ohm at an oscillation frequency of 50Hz-20kHz.
2. Attenuator impedance : 600ohm
3. Electronic voltmeter
4. Frequency counter
5. Test disc
: CTS-1000(12cm),GRG-1211(8cm)
6. Jitter meter

Measurement conditions

Power supply voltage
AC120V(60Hz)

Measurement
output terminal : Speaker out
: Dummy load 6ohm

Radio input signal

AM modulation frequency : 400Hz
Modulation factor : 30%
FM modulation frequency : 400Hz
Frequency displacement : 22.5kHz

Frequency Range

AM 530kHz~1710kHz
FM 87.5MHz~108MHz

Standard measurement positions of volume and switch

Power : Standby (Light STANDBY Indicator)
Sub woofer VOL. : Minimum
Sound mode : OFF
Main VOL. : 0 Minimum
Traverse mecha set position : Disc 1
Mic MIX VOL : MAX
ECHO : OFF

Precautions for measurement

1. Apply 30pF and 33kohm to the IF sweeper output side and 0.082 F and 100kohm in series to the sweeper input side.
2. The IF sweeper output level should be made as low as possible within the adjustable range.
3. Since the IF sweeper is a fixed device, there is no need to adjust this sweeper.
4. Since a ceramic oscillator is used, there is no need to perform any MPX adjustment.
5. Since a fixed coil is used, there is no need to adjust the FM tracking.
6. The input and output earth systems are separated. In case of simultaneously measuring the voltage in both of the input and output systems with an electronic voltmeter for two channels, therefore, the earth should be connected particularly.
7. In the case of BTL connection amplifier, the minus terminal of speaker is not for earthing. Therefore, be sure not to connect any other earth terminal to this terminal. This system is of an OTL system.

<Confirm method of operation>

■ Check mode

All lighting FL display and reducing time operation of clock

<Setting method of all lighting FL display>

"STANDBY/ON" key is pushed while pushing "REC/REC MUTING" key by the stand-by state.

<Setting method of reducing time operation of clock>

FL display is put into the state of all lighting by the method of the above-mentioned, and "STANDBY/ON" key is pushed afterwards.

The clock display comes to advance during one minute a second in actual time when changing to this mode. Because other operation can do the normal operation, Uses for the confirmation of the operation of the timer function etc.

<Release method>

"STANDBY/ON" key is pushed while pushing "REC/REC MUTING" key.

■ All release of set content

All content of the item in the following set is returned to initial state. (State of factory shipment)

<Setting method>

"STANDBY/ON" key is pushed while pushing "REC SOURCE SELECTOR" key by the stand-by state.

[Set items]

Deletion of time setting

The setting of the timer is deleted.

The program of the program play is deleted.

The content of the registration of the listening editing and the program editing is deleted.

The repeat setting is turned off.

Release of disc lock

The unit of busy is adjusted to the changer mechanism side.

The play mode of changer mechanism is made a normal mode.

The pitch control setting is turned off.

The selection of the recording source is made DIGITAL of CD.

DUB-SPEED setting is made HIGH.

AUTO TRACK setting is turned ON.

TRACK SPACE setting is turned ON.

CONVERTER setting is turned ON.

D-IN SYNCHRO setting is START

FINALISE setting is ON

■ Service menu

The running operation and the version of the firmware can be confirmed by the undermentioned method.

<Setting method of service menu>

1. "STANDBY/ON" key is pushed while pushing "FINALIZE" key by the stand-by state.

2. When the blinking display of the disk distinction ends, "MENU" key is pushed.

The menu display changes if "MULTI JOG" knob of the main body is turned.

3. The execution of the each item is completed or either "CANCEL" key, "CD-RW STOP" key or "MENU" key is pushed when going out of the menu mode.

<Release method>

If "STANDBY/ON" key is pushed, and the power supply is turned off once, becomes a normal menu.

■ Running operation

When this mode is executed, the operation of the recording and the playback is repeated.
Please use to confirm operation.

It is necessary to put the recorded disk or CD-DA in tray 1 of changer mechanism beforehand to execute this item, and put CD-RW of the blank disk in recording mechanism.

<Setting method of running operation>

- 1."Service menu" is made to be displayed on the FL display referring to the above-mentioned.
- 2."SYSTEM_AGING" is made to turn "MULTI JOG" knob, and to be displayed on the FL display.
- 3.The undermentioned operation starts when "SET" key is pushed.

The undermentioned control becomes possible according to the content of the disk turned on to tray 1 of changer mechanism.

- * The time required of operation of running once
- * Movement frequency of pick-up

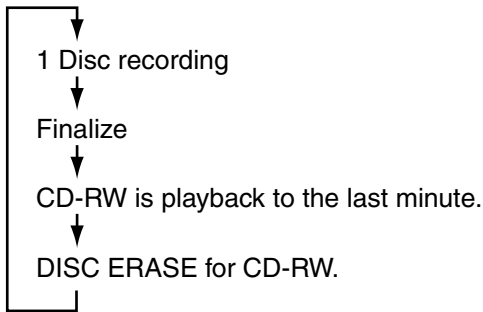

F L display becomes " * * * * ", and the frequency to which the running operation is done is displayed by the figure when "STOP" key is pushed to the running working or interrupted because of the error etc.

■ Display of version number

When this item is executed, version number "system controller", "CD recording unit", and "3CD changer unit" respectively is displayed in FL display for five seconds.
When five seconds pass, this mode is automatically made clear.

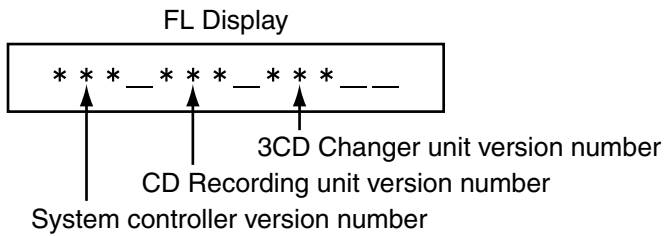

It is displayed instead of version number when failing in reading version number, "000".

Flow of functional operation until TOC read

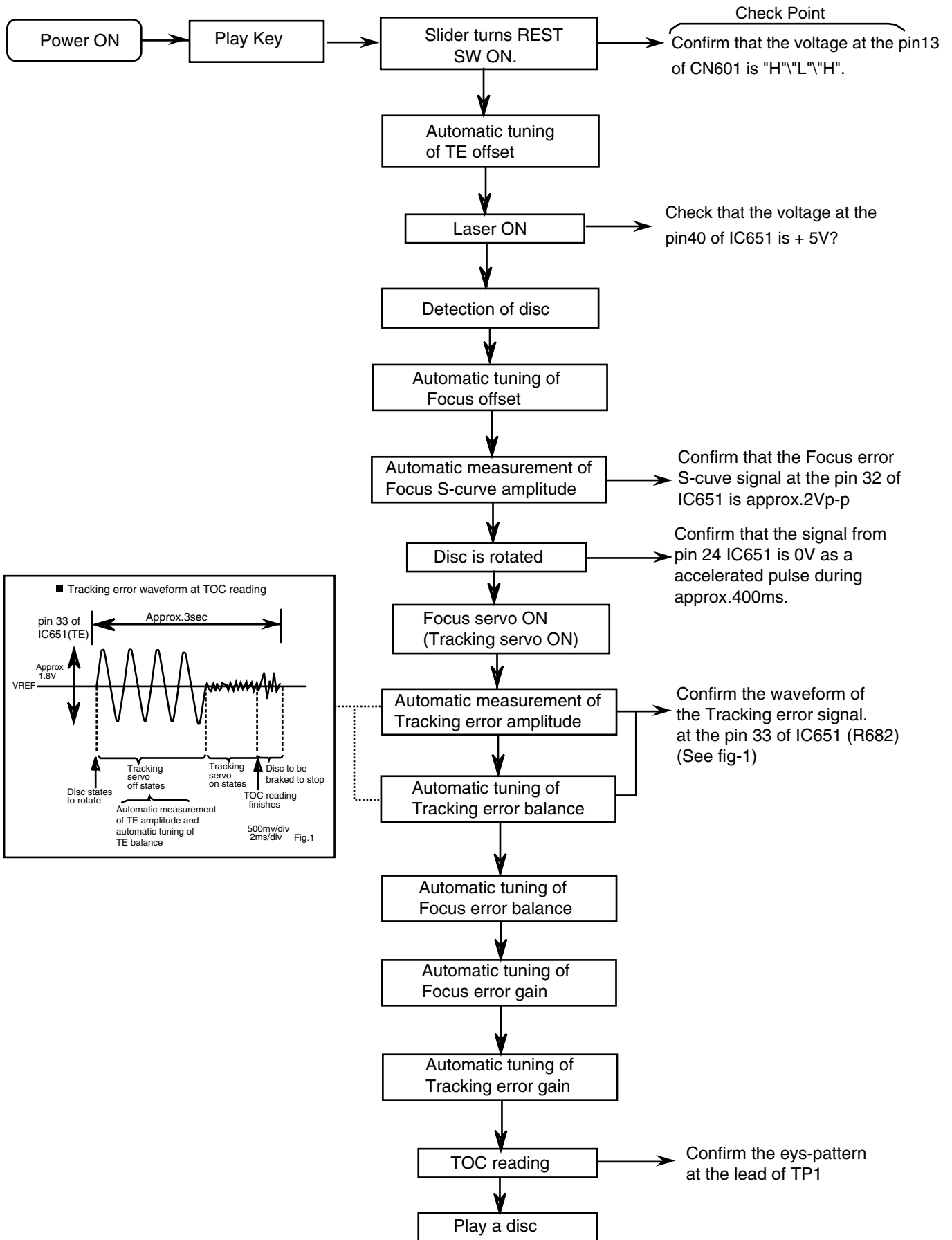

Maintenance of laser pickup

Replacement of laser pickup

(1) Cleaning the pick up lens

Before you replace the pick up, please try to clean the lens with a alcohol soaked cotton swab.

(2) Life of the laser diode

When the life of the laser diode has expired, the following symptoms will appear.

1. The level of RF output (EFM output : amplitude of eye pattern) will below.

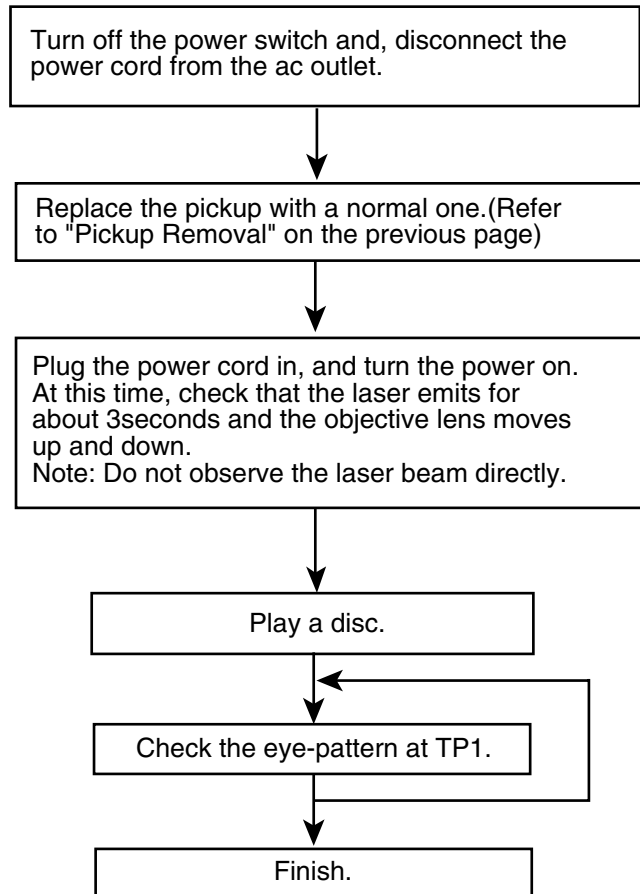
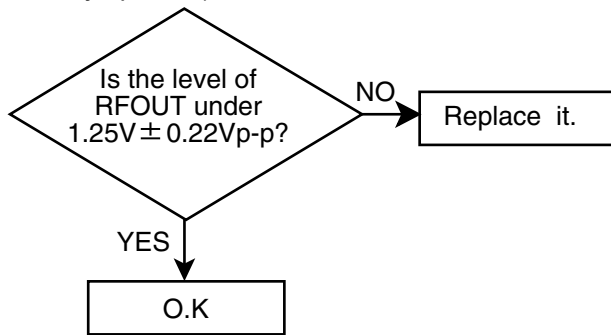

(3) Semi-fixed resistor on the APC PC board

The semi-fixed resistor on the APC printed circuit board which is attached to the pickup is used to adjust the laser power. Since this adjustment should be performed to match the characteristics of the whole optical block, do not touch the semi-fixed resistor.

If the laser power is lower than the specified value, the laser diode is almost worn out, and the laser pickup should be replaced.

If the semi-fixed resistor is adjusted while the pickup is functioning normally, the laser pickup may be damaged due to excessive current.

Description of major ICs

■ UPD780076GK502 (IC251) : Unit micon

1.Pin layout

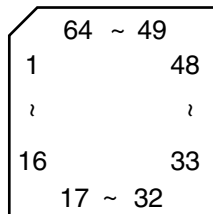

2.Pin function

Pin No.	Symbol	I/O	Description	Pin No.	Symbol	I/O	Description
1	ES2SCK	O	EEPROM serial clock output	36	/RESET	O	Reset signal output
2	E2SDL	O	EEPROM serial data I/O	37	XT2	O	Non connected
3	MCS	O	Synchronizatio /asynchronous system	38	XT1	I	Power supply input
4	MRDY	I	Ready signal input	39	IC	I	Not use(for flash micon)
5	ITRVP3	O	Tray play position3	40	X2	O	X'tal osc output
6	ITRVP2	O	Tray play position2	41	X1	I	X'tal osc input
7	ITRVP1	O	Tray play position1	42	VSS1	-	Connect to GND
8	ITRVsoc	I	Sub tray open/close	43	FLAG	O	FLAG for C1 error
9	VSS0	-	Connect to GND	42	VSS1	-	Connect to GND
10	VDD0	-	Power supply	43	FLAG	O	FLAG for C1 error
11	/REST	I	Rest switch	44	BLKCK	I	Sub code block clock signal input
12		-	No connect	45	/RFDET	I	RF signal level detection input
13		-	No connect	46	CAM_CW	O	Cam motor rotation clockwise
14	ICAMP1	O	Cam position 1	47	ACT_CCW	O	Actuator motor rotation counter clockwise
15	KCMND/TXD	I	Command signal input	48	ACT_CW	O	Actuator motor rotation clockwise
16	MSTAT/RXD	O	Status output	49		-	No connect
17	KCLK	I	Power supply	50	/EQX2	I	Surrond ings position detection in traverse
18	SUBQ	I	Sub Q data input				
19	CDCOPY	O	Connect to GND	51	ICAMP3	O	Cam position 3
20	SQCK	O	Sub Q clock output	52	ICAMP4	O	Cam position 4
21	CDINDEX	O	CD index output	53	/RESET	O	Reset signal output
22	CDTNO	I	Power supply	54	STAT	I	Status signal input
23	ICAMP2	O	Cam position 2	55	DMUTE	I	Digital mute signal input
24	VDD1	-	Power supply	56	P.ON	I	Power on signal input
25	AVSS	-	Connect to GND	57	MLD	I	Command load signal input
26	VDET_LEVEL	I	Key 1	58	MDATA	I	Command data input
27	KEY2	I	Key2 signal from running jig	59	MCLK	I	Command clock input
28	TRY3CLOSE	I	Tray 3 close signal input	60	CLKSW	-	No connect
29	TRY3OPEN	I	Tray 3 open signal input	61	/EQX4	-	Connect to GND
30	TRY2CLOSE	I	Tray 2 close signal input	62		-	No connect
31	TRY2OPEN	I	Tray 2 open signal input	63		-	No connect
32	TRY1OPEN	I	Tray 1 close signal input	64	DR_MUTE	O	DR mute signal output
33	TRY1CLOSE	I	Tray 1 open signal input				
34	AVREF	I	Reference power supply voltage				
35	CAM_CW	O	Cam motor rotation clockwise				

■ UPD784216AGF (IC701) : System micon

1. Terminal layout

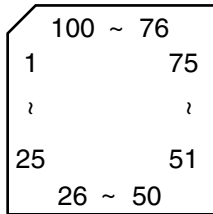

2. Pin function

Pin No.	Symbol	I/O	Function
1	PROTECT	I	Power amplifier output protect detection
2	SPK-RELAY	O	SPK-relay control signal
3	SURROUND	O	Surround output control signal
4	SMUTE	O	System mute control signal
5	POUT1	O	FL power supply control signal output
6	POUT2	O	Main power supply switching control
7	POUT3	O	FL regulator control output
8	STANDBY	O	Power amplifier control signal
9	VDD	-	Power supply
10	FL-RESET	O	FL reset signal output
11	FL-STB	O	FL strobe signal output
12	FL-CLK	O	FL clock output
13	FL-DATA	O	FL data output
14	LED-JOG	O	JOG dial LED control signal
15	LED-CDR/AMD	O	CDR/AMD LED control signal
16	LED-STBY	O	STBY LED control signal
17	LED-BMD	O	BMD LED control signal
18	NC	-	Connect to GND
19	NC	-	Connect to GND
20	NC	-	Connect to GND
21	NC	-	Connect to GND
22	TEST	-	TEST terminal
23	NC	-	Connect to GND
24	NC	-	Connect to GND
25	NC	-	Connect to GND
26	NC	-	Connect to GND
27	NC	-	Connect to GND
28	NC	-	Connect to GND
29	NC	-	Connect to GND
30	NC	-	Connect to GND
31	NC	-	Connect to GND
32	NC	-	Connect to GND
33	NC	-	Connect to GND
34	NC	-	Connect to GND
35	INH	O	Inhibit output signal
36	XKILL	O	Main clock of CPU stop signal
37	VDD	-	Power supply
38	X2	O	Connect to system main clock X'tal osc
39	X1	I	Connect to system main clock X'tal osc
40	VSS	-	Connect to GND
41	XT2	O	Connect to system sub clock X'tal osc
42	XT1	I	Connect to system sub clock X'tal osc
43	RESET	I	Reset signal input
44	REM	I	Remote control signal input
45	ZC4-DQSY	O	RF signal polarity specification terminal

Pin No.	Symbol	I/O	Function
46	CDR-RREQ	O	CDR request signal
47	RDCLK	I/O	Clock for data communication
48	NC	-	No connect
49	KEYP	I	Power on key input
50	+BCTL	-	No connect
51	AVDD	-	Power supply
52	AVREF0	I	Reference voltage
53	KEY0	I	Key control 0 input terminal
54	KEY1	I	Key control 1 input terminal
55	KEY2	I	Key control 2 input terminal
56	KEY3	I	Key control 3 input terminal
57	LOCK	I	Current detection of Motor control driver IC
58	VER	I	Version swching input
59	SAFE0	I	Over current detection input 0
60	SAFE1	I	Over current detection input 1
61	AVSS	-	Connect to GND
62	JOGB	O	Jog dial control signal output B
63	JOGA	O	Jog dial control signal output A
64	AVREF1	O	Power supply terminal
65	CDR-DATAI	I	Data communication for CDR input signal
66	CDR-DATAO	O	Data communication for CDR output signal
67	CDR-CLK	I/O	Clock for data communication
68	ZC4-MSTAT	I	Status input signal from CD unit micon
69	ZC4-KCMD	O	Command output signal to CD unit micon
70	NC	-	No connect
71	ZC4-RESET	O	CD chnger CPU reset
72	NC	-	No connect
73	ZC4-SUBC	I	CD SUB code data input
74	NC	-	No connect
75	ZC-SBCK	I/O	Bit clock for CD data communication
76	CDR-SREQ	O	Request signal for CDR unit
77	CDR-SRDY	O	Stand-by signal for CDR unit
78	CDR-RESET	O	Reset signal for CDR unit
79	VOL-DATA	O	Data output terminal
80	VOL-CLK	O	Clock signal output terminal
81	CDRMON	O	Signal input swiching for CDR
82	MIXOUT	O	Fanction swiching
83	VOLIN	I	VOL data input
84	FTU	O	Tuner control signal output
85	RDDA	I	Radio data input
86	TUDATA	I/O	Tuner data output
87	TUSTB	I/O	Tuner strobe signal
88	TUCLK	I/O	Clock for tuner data cominnucation
89	STEREO	I	Stereo indicator detection
90	LINEOUT-MUTE	O	Line out mute signal
91	DINCD	O	Dagital data control signal for CD
92	DINAUX	O	Dagital data control signal for fanction
93	PASWOP	I	Panel sw detection at open
94	PASWCL	I	Panel sw detection at close
95	PASWMIO	-	No connect
96	MT01	O	Panel motor drive control output 1
97	MT02	O	Panel motor drive control output 2
98	NC	-	No connect
99	NC	-	No connect
100	VSS	-	Connect to GND

■ MN662790RSC(IC651):Digital servo & processor

1.Pin layout

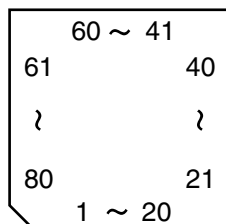

2.Pin function

MN662790RSC (1/2)

Pin No.	Symbol	I/O	Description
1	BCLK	O	Bit clock output for SRDATA
2	LRCK	O	Identifying signal output of L,R
3	SRDATA	O	Serial data output
4	DVDD1	-	Power supply for digital circuit
5	DVSS1	-	Connect to ground for digital circuit
6	TX	O	Digital audio interface output signal
7	MCLK	I	Micom command clock signal input
8	MDATA	I	Micom command data signal input
9	MLD	I	Micom command load signal input L:load
10	SENSE	-	Non connect
11	FLOCK	-	Non connect
12	TLOCK	-	Non connect
13	BLKCK	O	Sub code block clock signal (Command execution : CD-TEXT data readout enabling signal (DQSY) output)
14	SQCK	I	Export clock signal input for sub code Q register
15	SUBQ	O	Sub code Q data output
16	DMUTE	I	Muting input H:muting
17	STAT	O	Status signal output
18	LSI_RST	I	Reset signal input L:reset
19	SMCK	O	Clock signal output MSEL is H : 8.4672 MHz MSEL is L : 4.2336 MHz
20	CSEL	I	Oscillation frequency specification terminal H:33.8688 MHz L:16.9344 MHz
21	TEST2	-	TEST2 terminal usually : open
22	TVD	O	Traverse drive output
23	PC	-	Non connect
24	ECM	O	Spindle motor drive signal output (Compulsion mode output)
25	ECS	O	Spindle motor drive signal output (Servo error signal output)
26	VDETMON	-	Non connect
27	TRD	O	Tracking drive signal output
28	FOD	O	Focus drive signal output
29	VREF	-	Reference voltage for DA output section
30	FBAL	O	Focus balance adjust signal output
31	TBAL	O	Tracking balance adjust signal output
32	FE	I	Focus error signal input (analog input)
33	TE	I	Tracking error signal input (analog input)
34	RFENV	I	RF Envelope signal input (analog input)
35	TEST3	I	TEST3 Terminal usually : Fixation L
36	OFT	I	Off track signal input H : off track
37	TRCRS	I	Track cross signal input (analog input)
38	RFDET	I	RF detection signal input L : detection
39	BDO	I	Dropout signal input H : dropout
40	LDON	-	Non connect

2.Pin function

MN662790RSC (2/2)

Pin No.	Symbol	I/O	Functions
41	PLL2	I/O	Terminal for loop filter characteristic switch for PLL
42	DSLBD	-	Non connect
43	WVEL	-	Non connect
44	ARF	I	RF Signal output
45	IREF	I	Standard electric current input terminal
46	DRF	I	Bias terminal for DSL
47	DSL2	I/O	Loop filter terminal for DSL
48	PLL	I/O	Loop filter terminal for PLL
49	VCO	I/O	Loop filter terminal for VCO
50	AVDD2	-	Power supply terminal for analog circuit
51	AVSS2	-	Connect to ground terminal for analog circuit
52	EFM	-	Non connect
53	DSL	O	PLL extraction clock output
54	VCO2	I/O	Loop filter terminal for VCO
55	SUBC	O	Sub code serial output
56	SBCK	I	Clock signal input for sub code serial output
57	VSS	-	Connect to ground terminal for oscillation circuit
58	X1	I	Oscillation circuit input terminal f=16.9344 MHz, 33.8688 MHz
59	X2	O	Oscillation circuit output terminal f=16.9344 MHz, 33.8688 MHz
60	VDD	-	Power supply terminal for oscillation circuit
61	BYTCK	-	Non connect
62	LDON	O	Laser ON signal output H : ON
63	GCTRL	O	General I/O port
64	IPFLAG	-	Non connect
65	FLAG	O	Flag signal output
66	CLVS	-	Non connect
67	CRC	-	Non connect
68	DEMPH	O	De-emphasis detection signal output
69	RESY	-	Non connect
70	IOSEL	I	Mode switch terminal
71	TEST	I	TEST terminal usually : H
72	AVDD1	-	Power supply terminal for analog circuit (for audio output section)
73	OUTL	O	Lch audio output
74	AVSS1	-	Connect to ground terminal for analog circuit (for audio output section)
75	OUTR	O	Rch audio output
76	DQSY	I	RF signal polarity specification terminal
77	VCC5V	-	Power supply terminal (5V)
78	PSEL	O	IOSEL=H TEST terminal IOSEL=L SRDATA input
79	MSEL	O	IOSEL=H SMCK terminal output (frequency switch terminal) IOSEL=L LRCK input
80	SSEL	O	IOSEL=H SUBQ terminal output mode switch terminal IOSEL=L BCLK input

■ AN22000A-W (IC601) : RF head amp.

1. Pin layout

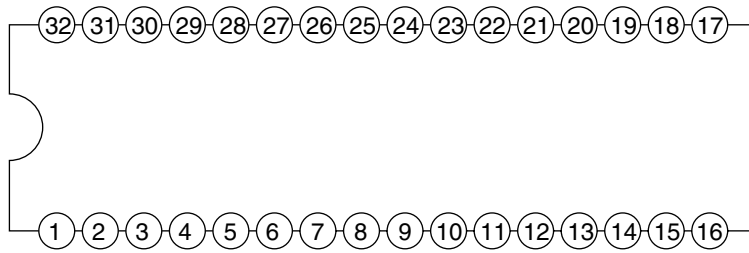

2. Block diagram

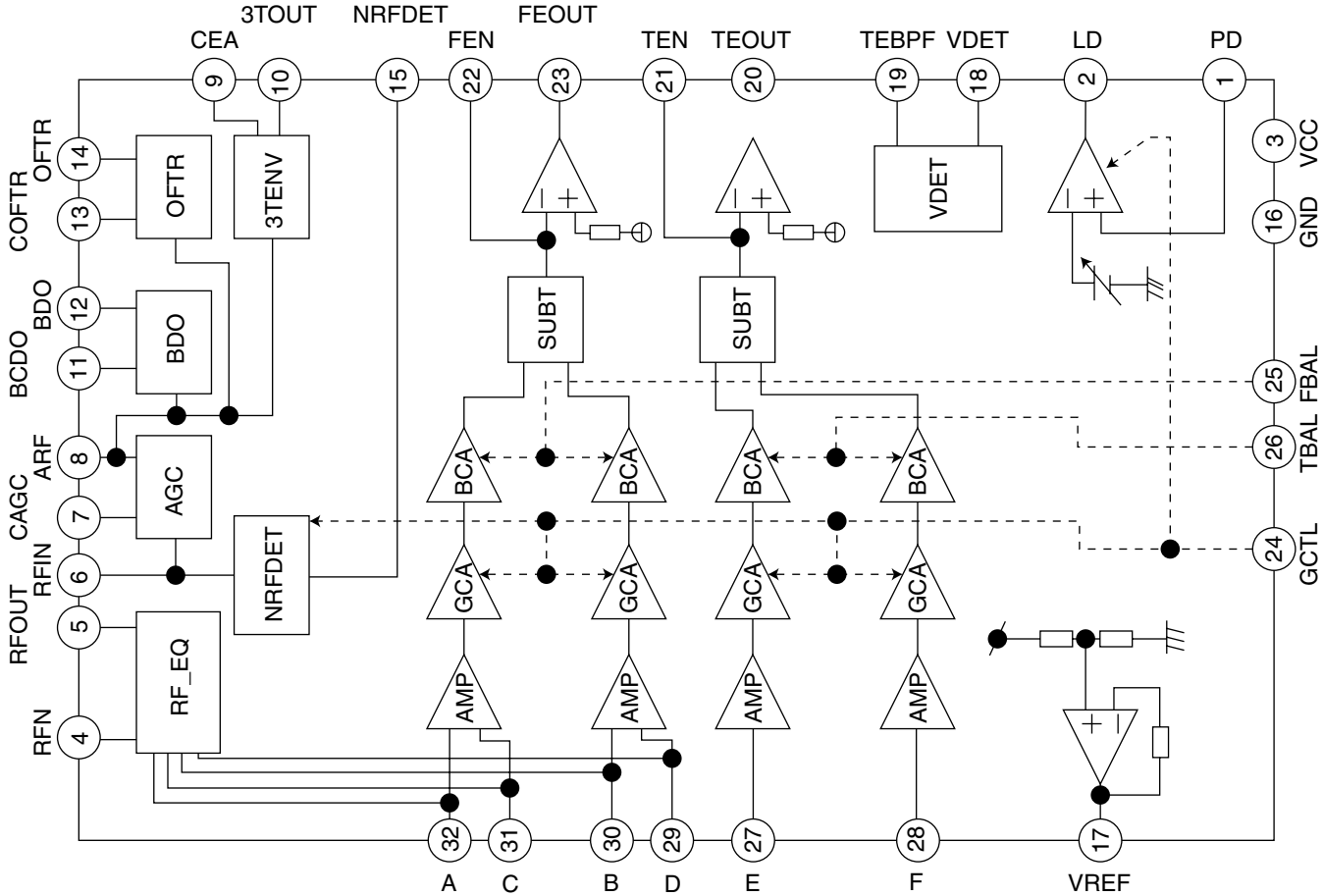

3. Pin function

Pin No.	Function	Pin No.	Function
1	APC amp input terminal.	17	VREF output terminal.
2	APC amp output terminal.	18	VDET output terminal.
3	Power supply.	19	VDET input terminal.
4	RF amp negative input terminal.	20	TE amp. output terminal.
5	RF amp output terminal.	21	TE amp. negative input terminal.
6	AGC input terminal.	22	FE amp. negative input terminal.
7	AGC loop filter capacitor connection terminal.	23	FE amp. output terminal.
8	AGC output terminal.	24	GCTL & APC terminal.
9	Capacitor connection terminal for HPF-amp.	25	FBAL control terminal.
10	3TENV output terminal.	26	TBAL control terminal.
11	Capacitor connection terminal for RF envelope detection.	27	Tracking signal input terminal 1.
12	BDO output terminal.	28	Tracking signal input terminal 2.
13	Capacitor connection terminal for RF envelope detection.	29	Focus signal input terminal 4.
14	OFTR output terminal.	30	Focus signal input terminal 3.
15	NRDET output terminal.	31	Focus signal input terminal 2.
16	Ground terminal.	32	Focus signal input terminal 1.

■ BR24C01AFV-W-X (IC201) : EEPROM

1.Pin layout

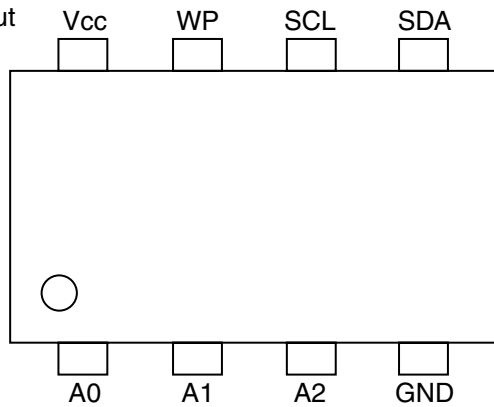

2.Block diagram

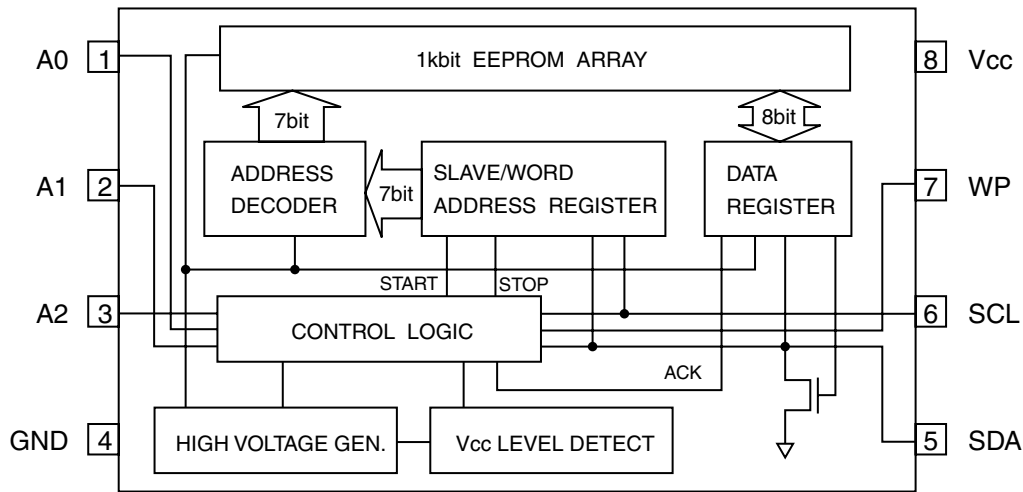

3.Pin function

Pin name	I/O	Function
Vcc	-	Power supply
GND	-	Ground (0v)
A0,A1,A2	IN	Slave address set
SCL	IN	Serial clock input
SDA	IN / OUT	Slave and word address, serial data input, serial data output *1
WP	IN	Write protect input

*1 An open drain output requires a pull-up resistor.

■ BU4066BCF-X (IC304,IC305) : Switch

1.Pin layout

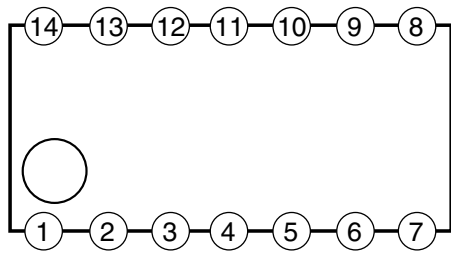

2.Block diagram

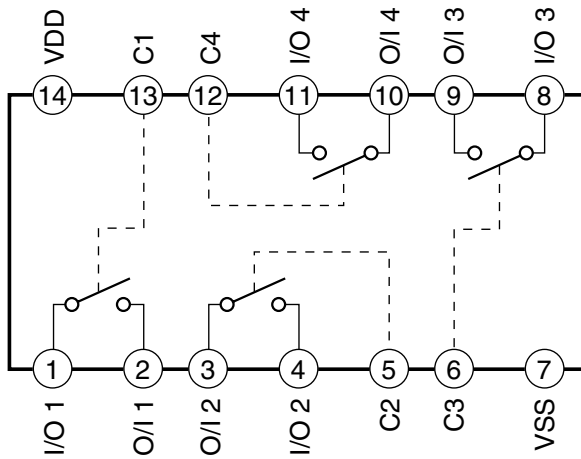

■ KIA78S06P-T (IC702,IC703) : Regulator

1. Pin layout

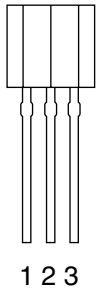

2. Block diagram

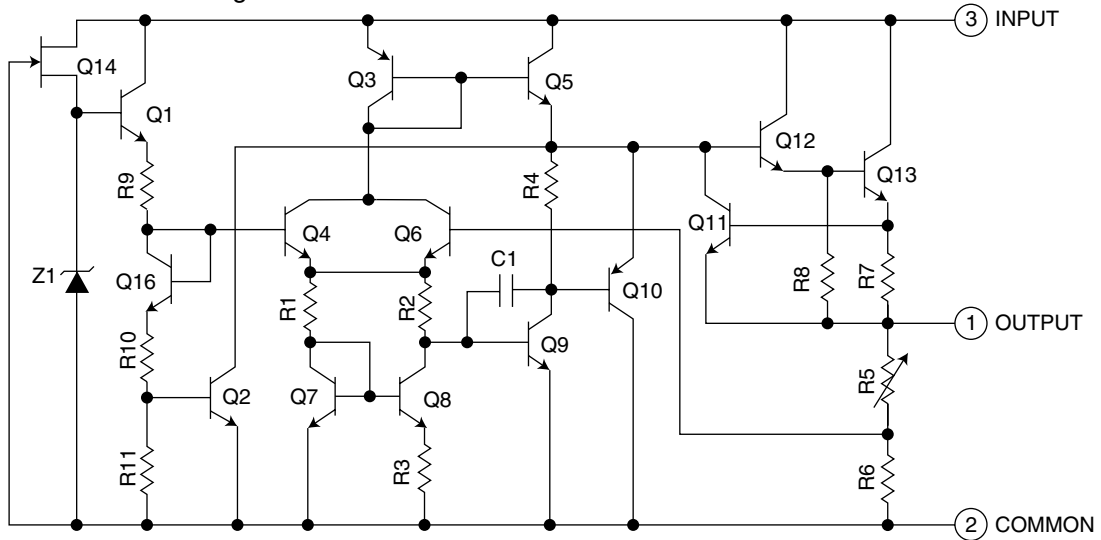

■ TA8409S (IC704) : Motor driver

1.Pin layout

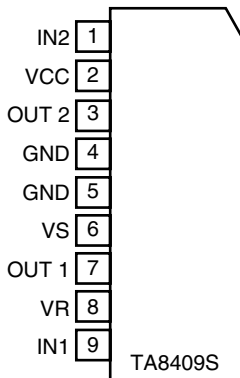

2.Pin function

INPUT		OUTPUT		MODE
IN1	IN2	OUT1	OUT2	MOTOR
0	0	∞	∞	STOP
1	0	H	L	CW/CCW
0	1	L	H	CCW/CW
1	1	L	L	BRAKE

GP1U261X (IC851) : Receiver

1. Pin layout

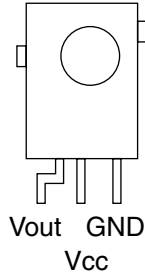

2. Block diagram

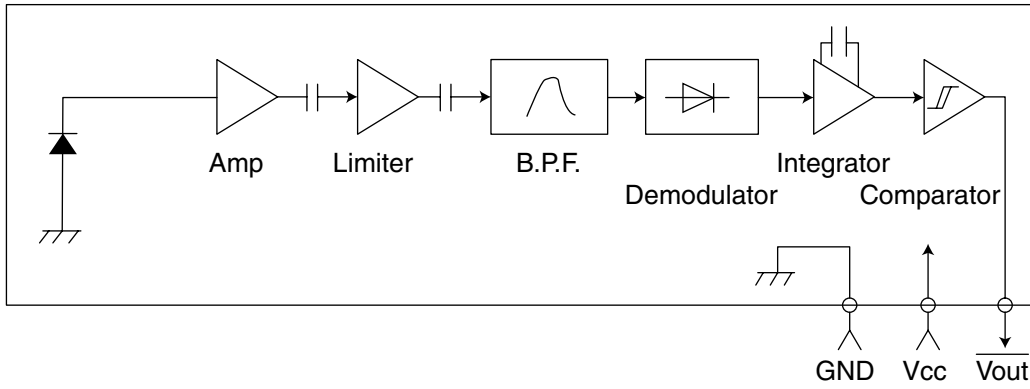

NJM4580D (IC301,IC302) : LPF, Mic and H.phone amp.

1. Terminal layout

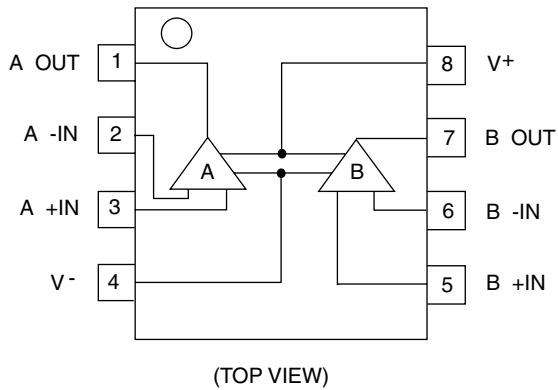

2. Block diagram

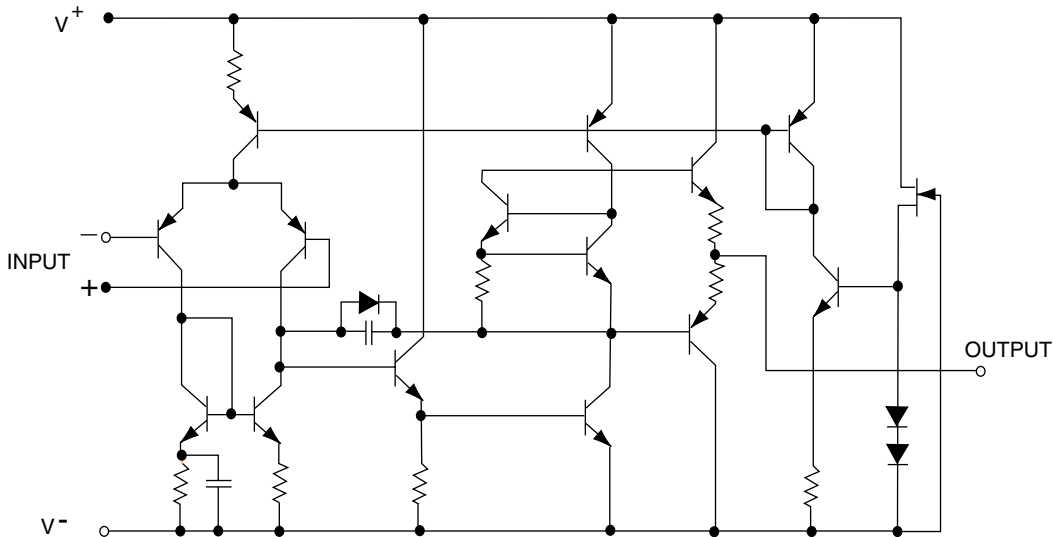

■ LA1838 (IC1): FM AM IF AMP&detector, FM MPX decoder

1. Block Diagram

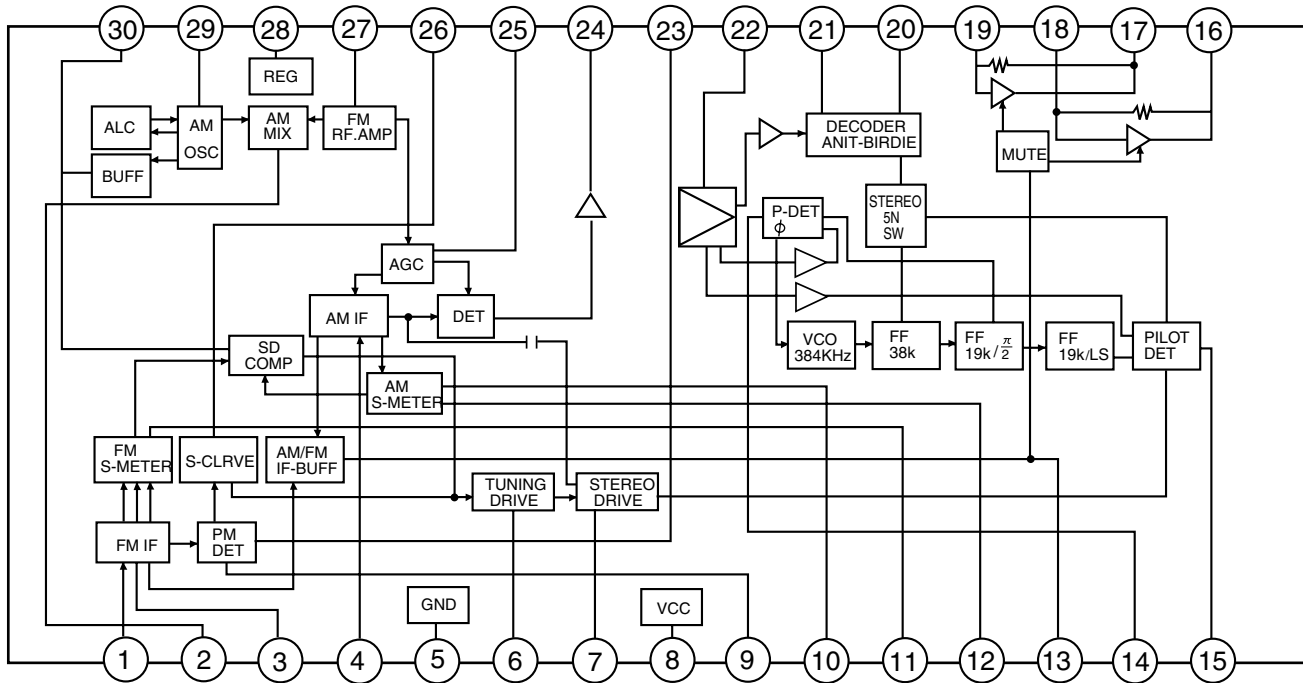

2. Pin Function

Pin No.	Symbol	I/O	Function	Pin No.	Symbol	I/O	Function
1	FM IN	I	This is an input terminal of FM IF signal.	16	L OUT	O	Left channel signal output.
2	AM MIX	O	This is an out put terminal for AM mixer.	17	R OUT	O	Right channel signal output.
3	FM IF	I	Bypass of FM IF	18	L IN	I	Input terminal of the left channel post AMP.
4	AM IF	I	Input of AM IF Signal.	19	R IN	I	Input terminal of the right channel post AMP.
5	GND	—	This is the device ground terminal.	20	RO	O	Mpx Right channel signal output.
6	TUNED	O	When the set is tuning, this terminal becomes "L".	21	LO	O	Mpx Left channel signal output.
7	STEREO	O	Stereo indicator output. Stereo "L", Mono: "H"	22	IF IN	I	Mpx input terminal
8	VCC	—	This is the power supply terminal.	23	FM OUT	O	FM detection output.
9	FM DET	—	FM detect transformer.	24	AM DET	O	AM detection output.
10	AM SD	—	This is a terminal of AM ceramic filter.	25	AM AGC	I	This is an AGC voltage input terminal for AM
11	FM VSM	O	Adjust FM SD sensitivity.	26	AFC	—	This is an output terminal of voltage for FM-AFC.
12	AM VSM	O	Adjust AM SD sensitivity.	27	AM RF	I	AM RF signal input.
13	MUTE	I/O	When the signal of IF REQ of IC121(LC72131) appear, the signal of FM/AM IF output. //Muting control input.	28	REG	O	Register value between pin 26 and pin28 desides the frequency width of the input signal.
14	FM/AM	I	Change over the FM/AM input. "H" :FM, "L" : AM	29	AM OSC	—	This is a terminal of AM Local oscillation circuit.
15	MONO/ST	O	Stereo : "H", Mono: "L"	30	OSC BUFFER	O	AM Local oscillation Signal output.

■ LA6541-X (IC801) : Servo driver

1. Pin Layout & block diagram

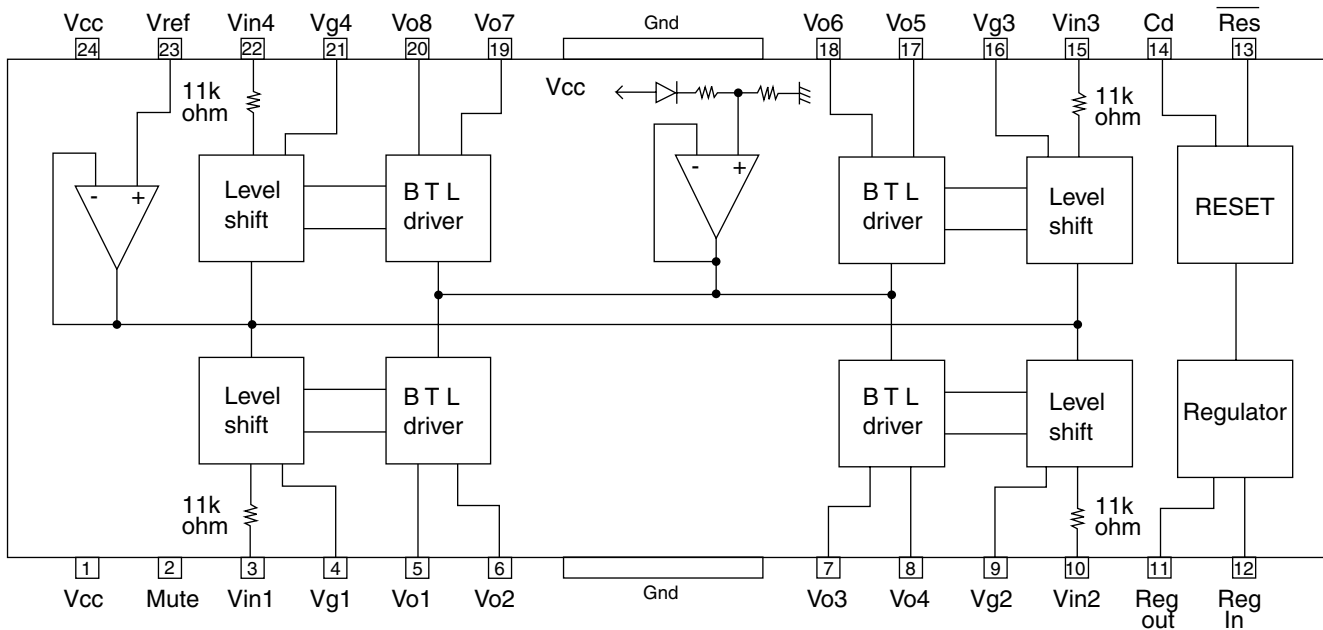

2. Pin function

Pin No.	Symbol	Function
1	Vcc	Power supply (Shorted to pin 24)
2	Mute	All BTL amplifier outputs ON/OFF
3	Vin1	BTL AMP 1 input pin
4	Vg1	BTL AMP 1 input pin (For gain adjustment)
5	Vo1	BTL AMP 1 input pin (Non inverting side)
6	Vo2	BTL AMP 1 input pin (Inverting side)
7	Vo3	BTL AMP 2 input pin (Inverting side)
8	Vo4	BTL AMP 2 input pin (Non inverting side)
9	Vg2	BTL AMP 2 input pin (For gain adjustment)
10	Vin2	BTL AMP 2 input pin
11	Reg Out	External transistor collector (PNP) connection. 5V power supply output
12	Reg In	External transistor (PNP) base connection
13	Res	Reset output
14	Cd	Reset output delay time setting (Capacitor connected externally)
15	Vin3	BTL AMP 3 input pin
16	Vg3	BTL AMP 3 input pin (For gain adjustment)
17	Vo5	BTL AMP 3 output pin (Non inverting side)
18	Vo6	BTL AMP 3 output pin (Inverting side)
19	Vo7	BTL AMP 4 output pin (Inverting side)
20	Vo8	BTL AMP 4 output pin (Non inverting side)
21	Vg4	BTL AMP 4 output pin (For gain adjustment)
22	Vin4	BTL AMP 4 output pin
23	Vref	Level shift circuit's reference voltage application
24	Vcc	Power supply (Shorted to pin 1)

■ LC72136N (IC2) : PLL frequency synthesizer

1. Pin layout

XT	1	22	XT
FM/AM	2	21	GND
CE	3	20	LPFOUT
DI	4	19	LPFIN
CLOCK	5	18	PD
DO	6	17	VCC
FM/ST/VCO	7	16	FMIN
AM/FM	8	15	AMIN
	9	14	
	10	13	IFCONT
SDIN	11	12	IFIN

2. Block diagram

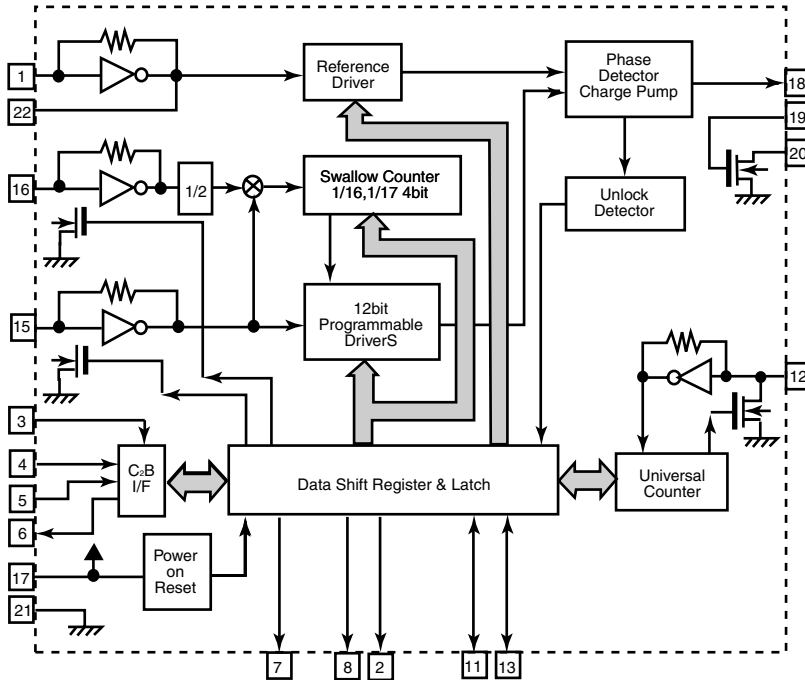

3. Pin function

Pin No.	Symbol	I/O	Function	Pin No.	Symbol	I/O	Function
1	XT	I	X'tal oscillator connect (75kHz)	12	IFIN	I	IF counter signal input
2	FM/AM	O	LOW:FM mode	13	IFCONT	O	IF signal output
3	CE	I	When data output/input for 4pin(input) and 6pin(output): H	14		-	Not use
4	DI	I	Input for receive the serial data from controller	15	AMIN	I	AM Local OSC signal output
5	CLOCK	I	Sync signal input use	16	FMIN	I	FM Local OSC signal input
6	DO	O	Data output for Controller Output port	17	VCC	-	Power supply(VDD=4.5-5.5V) When power ON:Reset circuit move
7	FM/ST/VCO	O	"Low": MW mode	18	PD	O	PLL charge pump output(H: Local OSC frequency Height than Reference frequency. L: Low Agreement: Height impedance)
8	AM/FM	O	Open state after the power on reset	19	LPFIN	I	Input for active lowpassfilter of PLL
9	LW	I/O	Input/output port	20	LPFOUT	O	Output for active lowpassfilter of PLL
10	MW	I/O	Input/output port	21	GND	-	Connected to GND
11	SDIN	I/O	Data input/output	22	XT	I	X'tal oscillator(75KHz)

■ M66004FP-X(IC852):FL driver

1. Block Diagram

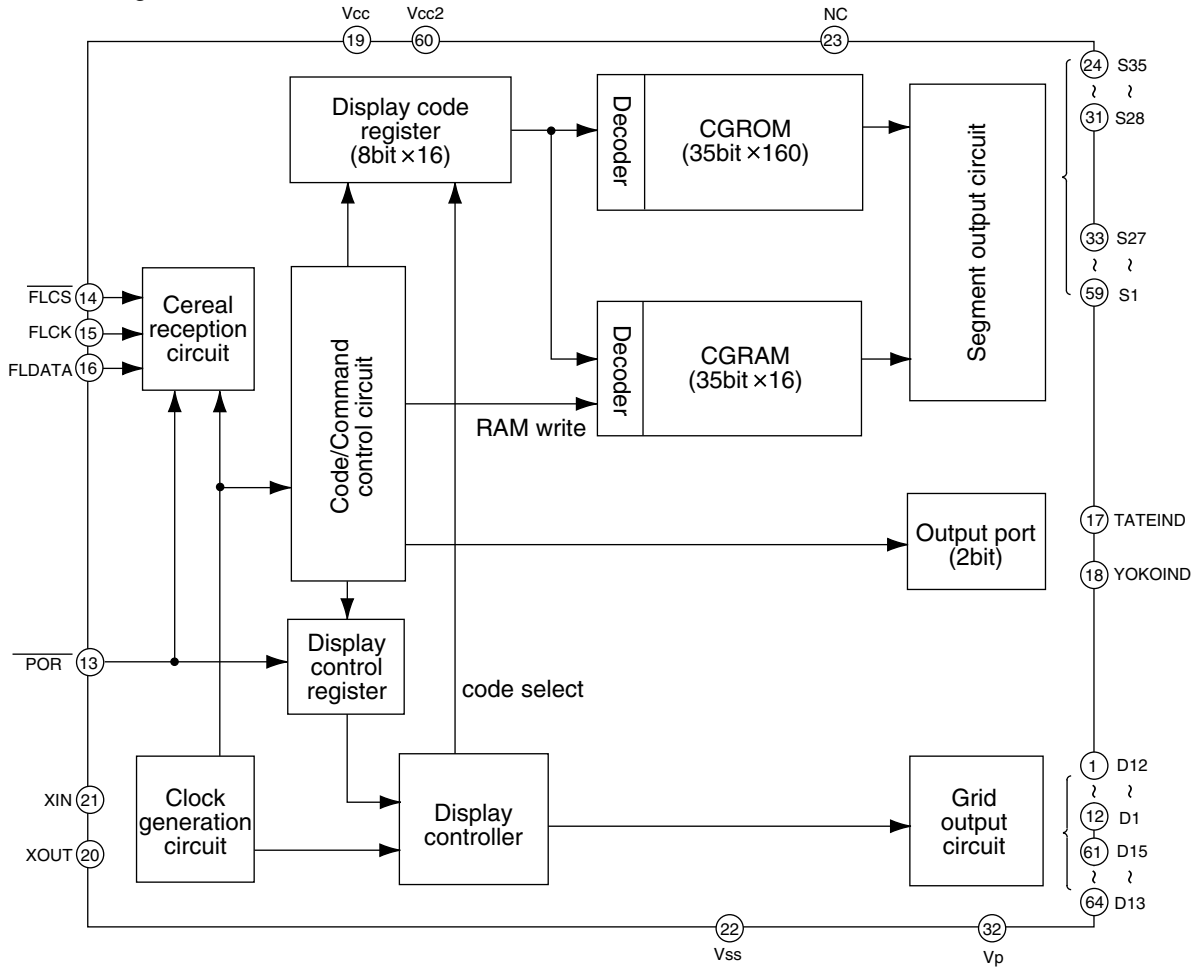

2. Pin function

Pin.No.	Symbol	I/O	Function
1	D11		Non connect
2~12	D10~D0	O	FL grid control signal output.
13	POR	I	FL Driver chip select.
14	FLCS	I	Chip select signal input.
15	FLCK	I	Shift clock signal input.
16	FLDATA	I	Serial data input.
17	TATEIND	O	Indicator control signal output.
18	YOKOIND	O	Indicator control signal output.
19	VCC1	-	Power supply for internal logic.
20	XOUT	O	Clock signal output.
21	XIN	I	Clock signal input.
22	VSS	-	Connect to GND.
23	S35	-	Non connect.
24~31	S34~S27	O	FL Segment control signal output.
32	VP	-	Power supply.
33~59	S26~S0	O	FL Segment control signal output.
60	VCC2	-	Power supply for grid output and segment output.
61~64	D15~D12	O	FL grid control signal output.

■ STK402-030 (IC101) : Power amp

1.Pin layout

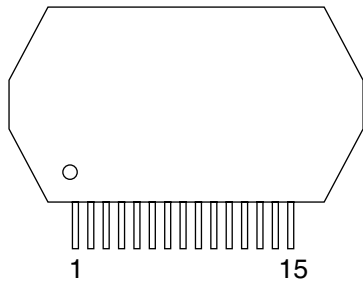

2.Block diagram

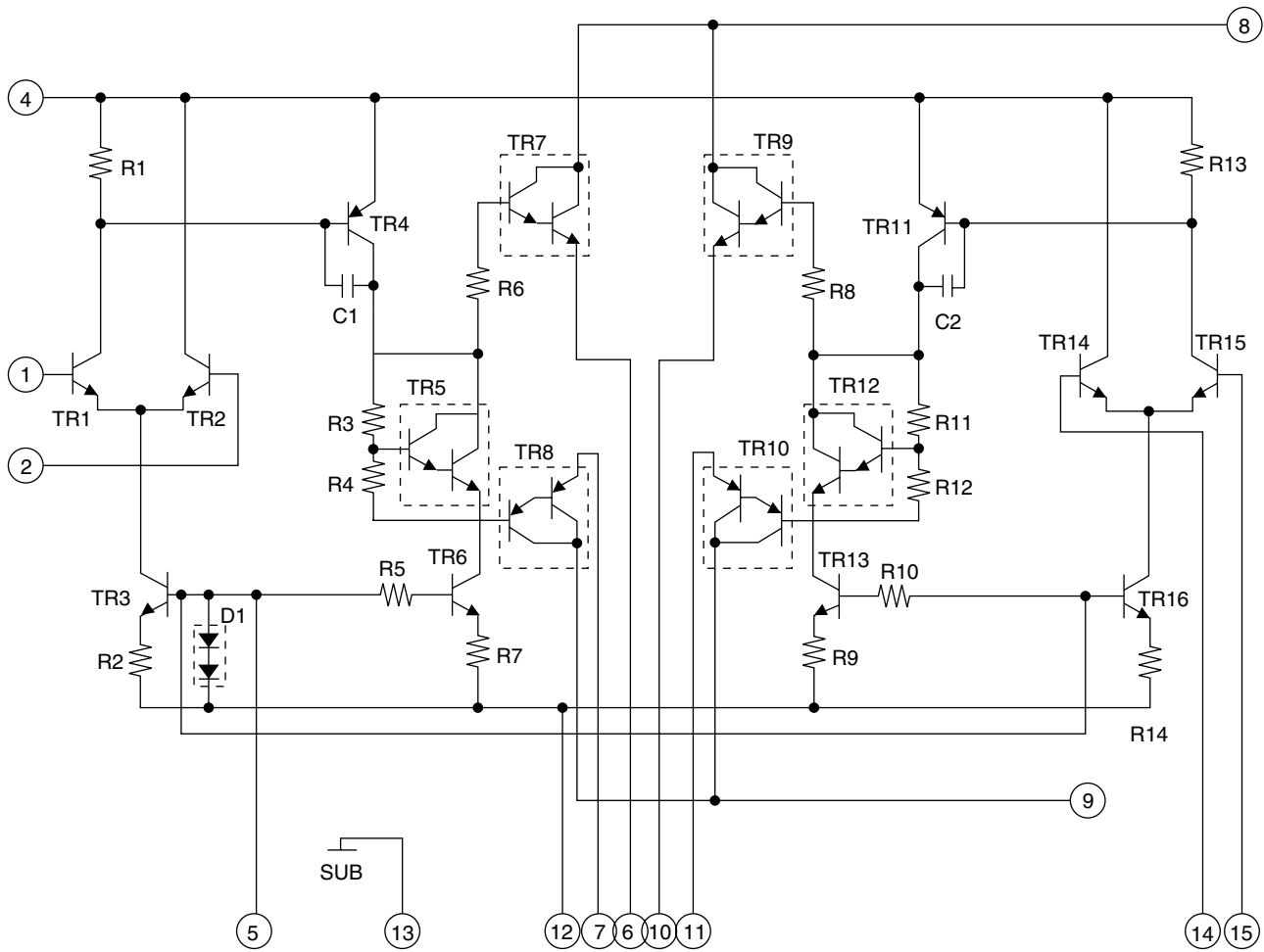

TC74HCT04AF-X (IC652) : Inverter

1. Block diagram

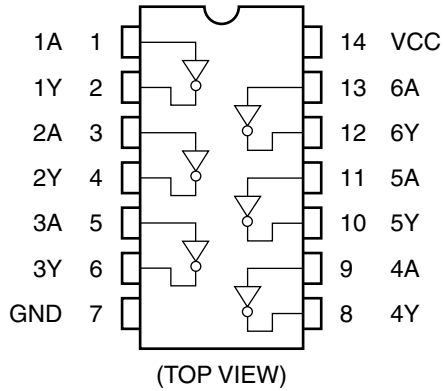

2. True table

A	Y
L	H
H	L

XC62HR3502P-X (IC291) : Regulator

1. Pin layout

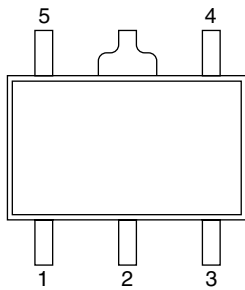

2. Block diagram

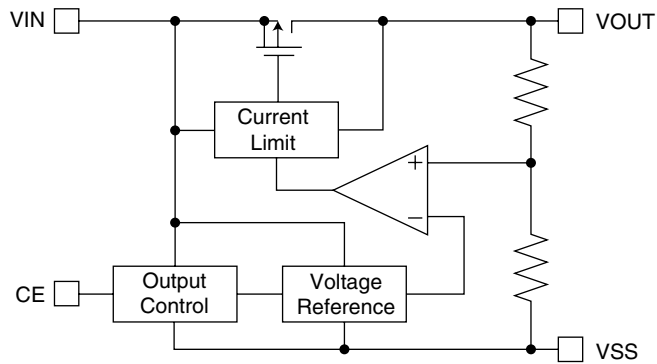

3. Pin function

Pin No.	Symbol	Function
1	VSS	Ground
2	VIN	Supply voltage input
3	CE	Chip enable
4	NC	Non connect
5	VOUT	Regulated output voltage

■ TDA7439 (IC303) : Control volume

1.Pin layout

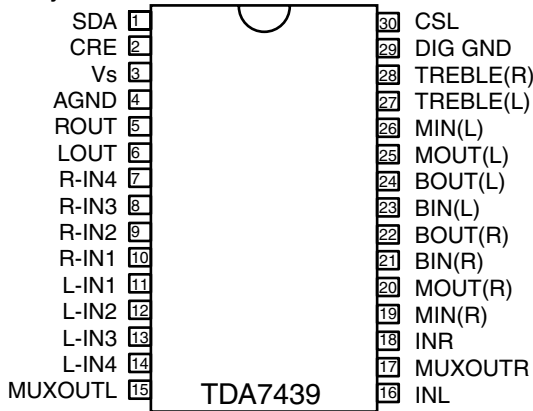

2.Block diagram

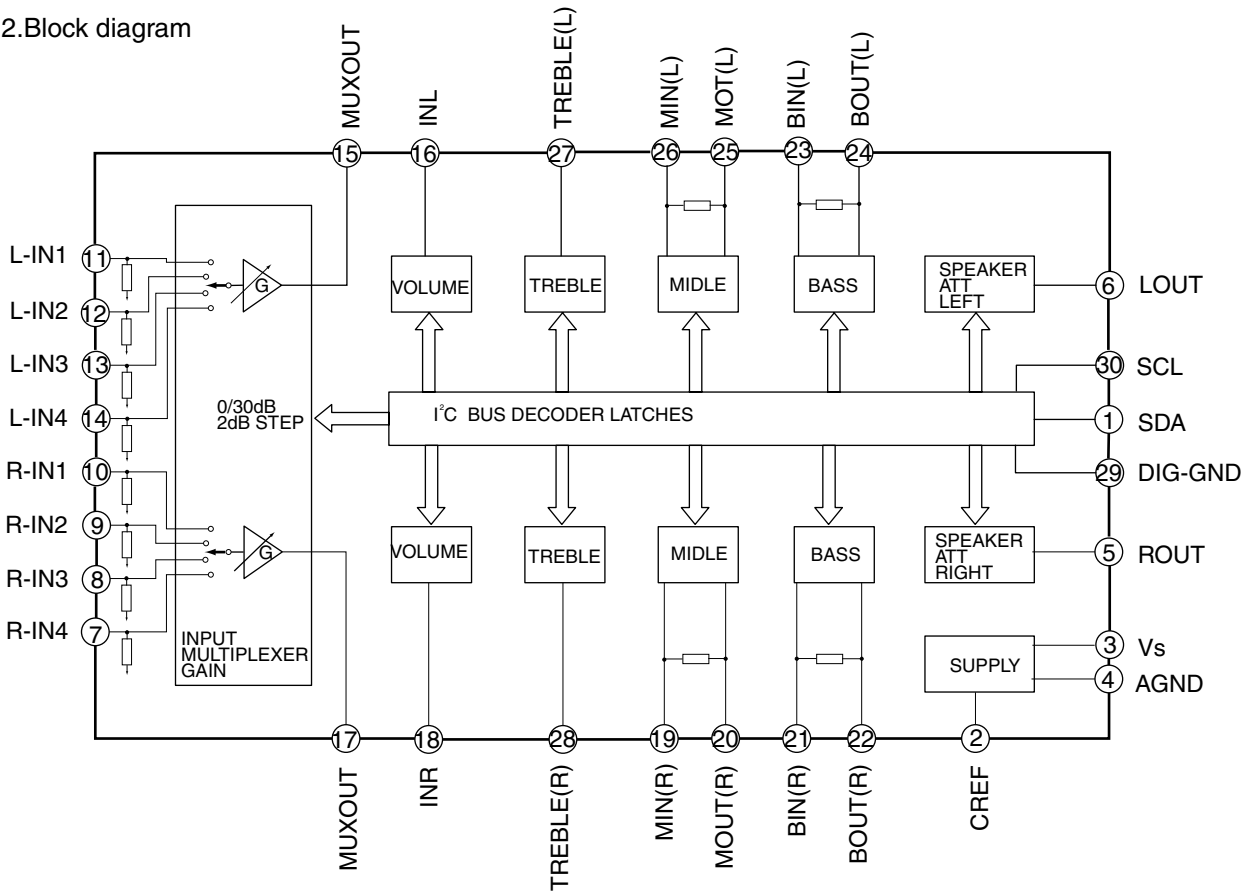

< MEMO >



JVC

VICTOR COMPANY OF JAPAN, LIMITED
AUDIO & COMMUNICATION BUSINESS DIVISION
PERSONAL & MOBILE NETWORK BUSINESS UNIT. 10-1, 1chome, Ohwatari-machi, Maebashi-city, 371-8543, Japan